

# E2 Series

## ELECTRIC SCISSOR LIFTS



*New Workstation in the Sky™  
Products Boost Productivity*



*Compact Sizes  
for Door Clearance*



*Tight Turning Radius*

**1932E2**  
**2032E2**  
**2632E2**  
**2646E2**  
**3246E2**

[www.jlg.com](http://www.jlg.com)



# Get the Power To Do More.

With the right combination of JLG innovations, the E2 Series scissor lifts help you work faster, smarter and easier than ever before. With optimum function speeds for both travel and lifting, higher duty cycles that keep you on the job longer, and a compact design that gets you through the door and up to the height you need to reach—the E2 Series is ready to work when you are.

The E2 Series offers the most popular machine sizes, performance features and capabilities demanded by users, and provides powerful productivity at an economical price. And now, with optional proportional JLG SMART System® controls on selected models and our revolutionary new Workstation in the Sky™ option packages, the E2 Series can provide you with a powerful advantage on any job.

## Narrow Aisle Models

*When doorway clearance is necessary, JLG provides three models—1932E2, 2032E2 and 2632E2—that can navigate through narrow aisles and other confined spaces to efficiently access hard-to-reach areas for more productive aerial maintenance projects.*

## Best on-the-Job Performance

*The JLG E2 Series is an economical, reliable series of scissor lifts designed to meet the demands of any jobsite. The E2 Series scissor lifts provide long duty cycles for longer operating times, tight turning radius for maneuvering and positioning, and a rugged design with a quality finish to withstand jobsite abuse. All E2 Series scissor lifts receive JLG powder coat paint and nickel plated pins for durability.*

## Efficient Serviceability

*JLG Model E2 scissor lifts are specifically designed for efficient servicing and maintenance. Electrical and hydraulic components are housed in swing-out doors in one convenient location for added ease of access. And, when new parts are required, JLG's PartsPlus® program can have them delivered to your door, usually within 24 hours.*



### Dimensional Data\*\*

- A. Platform Height —Elevated
- Lowered
- B. Platform Railing Height\*
- C. Overall Height
- With Rails Folded
- D. Platform Dimensions
- Platform Extension
- E. Overall Length
- F. Overall Width
- G. Wheelbase
- Ground Clearance
- Tire Size

### Performance Data

- Platform Capacity
- Capacity on Deck Extension
- Lift/Lower Time
- Maximum Drive Height
- Drive Speed—Lowered
- Drive Speed—Elevated
- Gradeability
- Turning Radius (Inside)
- Turning Radius (Outside)

### Power System/Chassis

- Batteries
- Charger
- Electric Motor
- Pump
- Hydraulic Reservoir
- Brakes
- Gross Vehicle Weight\*\*

\*Special heights available. Consult factory.

\*\*Certain weights and dimensions may vary due to options

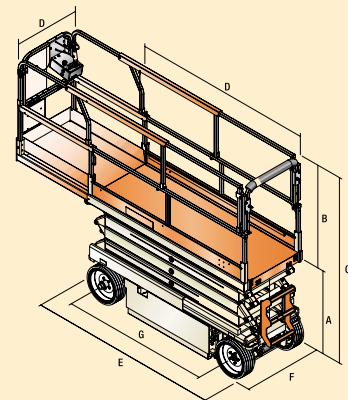

Model 1932E2	Model 2032E2	Model 2632E2	Model 2646E2	Model 3246E2
19 ft. (5.79 m)	20 ft. (6.10 m)	26 ft. (7.92 m)	26 ft. (7.92 m)	32 ft. (9.75 m)
3 ft. 3 in. (99 cm)	3 ft. 2 in. (97 cm)	3 ft. 10 in. (1.17 m)	3 ft. 10 in. (1.17 m)	4 ft. 3 in. (1.30 m)
3 ft. 3 in. (99 cm)	3 ft. 6 in. (1.07 m)	3 ft. 6 in. (1.07 m)	3 ft. 7.5 in. (1.11 m)	3 ft. 7.5 in. (1.11 m)
6 ft. 7.5 in. (2.02 m)	6 ft. 7.5 in. (2.02 m)	7 ft. 5.5 in. (2.27 m)	—	—
—	—	—	6 ft. (1.83 m)	6 ft. 5 in. (1.96 m)
31 in. x 64 in. (0.79 m x 1.63 m)	31 in. x 84 in. (0.79 m x 2.13 m)	31 in. x 84 in. (0.79 m x 2.13 m)	45 in. x 84 in. (1.14 m x 2.13 m)	45 in. x 84 in. (1.14 m x 2.13 m)
3 ft. (91 cm)	3 ft. (91 cm)	3 ft. (91 cm)	3 ft. (91 cm)	3 ft. (91 cm)
5 ft. 8.5 in. (1.74 m)	7 ft. 5 in. (2.26 m)	7 ft. 7.5 in. (2.32 m)	7 ft. 5 in. (2.26 m)	7 ft. 6.5 in. (2.30 m)
32 in. (81 cm)	32 in. (81 cm)	32 in. (81 cm)	46 in. (1.17 m)	46 in. (1.17 m)
4 ft. 4 in. (1.32 m)	5 ft. 8.5 in. (1.74 m)	5 ft. 8.5 in. (1.74 m)	5 ft. 8.5 in. (1.74 m)	5 ft. 8.5 in. (1.74 m)
2.75 in. (7 cm)	2.75 in. (7 cm)	3 in. (8 cm)	2.75 in. (7 cm)	3 in. (8 cm)
12.5 x 4 Non-Marking Solid	16 x 5 Non-Marking Solid	16 x 5 Non-Marking Solid	16 x 5 Non-Marking Solid	16 x 5 Non-Marking Solid
500 lb. (227 kg)	750 lb. (340 kg)	500 lb. (227 kg)	750 lb. (340 kg)	700 lb. (318 kg)
250 lb. (113 kg)	250 lb. (113 kg)	250 lb. (113 kg)	250 lb. (113 kg)	250 lb. (113 kg)
27/26 sec.	31/31 sec.	30/40 sec.	46/41 sec.	60/57 sec.
Full Height	Full Height	Full Height	Full Height	Full Height
2.5 mph (4.0 kph)	2.5 mph (4.0 kph)	2.25 mph (3.6 kph)	2.25 mph (3.6 kph)	2.0 mph (3.2 kph)
0.5 mph (0.8 kph)	0.5 mph (0.8 kph)	0.5 mph (0.8 kph)	0.5 mph (0.8 kph)	0.5 mph (0.8 kph)
25%	25%	25%	25%	25%
6 in. (15 cm)	3 ft. 3 in. (99 cm)	2 ft. 10 in. (86 cm)	3 ft. 8 in. (1.12 m)	3 ft. 9 in. (1.14 m)
5 ft. 8 in. (1.72 m)	8 ft. 4 in. (2.54 m)	8 ft. 4 in. (2.54 m)	9 ft. 3 in. (2.82 m)	9 ft. 7 in. (2.92 m)
4 x 6V 220 amp-hr	4 x 6V 220 amp-hr	4 x 6V 245 amp-hr	4 x 6V 220 amp-hr	4 x 6V 245 amp-hr
20 Amp Automatic	20 Amp Automatic	20 Amp Automatic	20 Amp Automatic	20 Amp Automatic
SCR 120/250V, 50/60HZ	SCR 120/250V, 50/60HZ	SCR 120/250V, 50/60HZ	SCR 120/250V, 50/60HZ	SCR 120/250V, 50/60HZ
3.5 HP (2.6 kW)	4.5 HP (3.4 kW)	4.5 HP (3.4 kW)	4.5 HP (3.4 kW)	4.5 HP (3.4 kW)
Single Section Gear	Single Section Gear	Single Section Gear	Single Section Gear	Single Section Gear
3 gal. (11.4 L)	4 gal. (15.2 L)	4.5 gal. (17.0 L)	4 gal. (15.2 L)	4 gal. (15.2 L)
Automatic Rear Wheel Parking	Automatic Rear Wheel Parking	Automatic Rear Wheel Parking	Automatic Rear Wheel Parking	Automatic Rear Wheel Parking
2,620 lb. (1,188 kg)	3,910 lb. (1,774 kg)	5,325 lb. (2,415 kg)	4,380 lb. (1,987 kg)	6,100 lb. (2,767 kg)

and to compliance with country standards.

## Standard Features

110V-AC Receptacle  
 Pothole Protection System  
 Joystick Drive/Steer Control  
 Moveable, Removable Platform  
 Control Box  
 Lanyard Attach Points  
 Positive Traction  
 3 Ft. Roll-Out Deck Extension  
 Forklift Pockets  
 220 Amp-Hour Batteries<sup>1</sup>  
 245 Amp-Hour Batteries<sup>2</sup>  
 1. Standard on 1932E2, 2032E2, 2646E2.  
 2. Standard on 2632E2, 3246E2.

20 Amp Automatic SCR Battery Charger  
 Non-Marking Tires  
 2 Degree Slope Alarm & Light  
 Hourmeter  
 Descent Alarm  
 Manual Descent Pull Cable  
 Scissor Maintenance Prop  
 Swing-Out Battery and  
 Hydraulic Compartments  
 Lifting/Tie Down Lugs  
 Fold-Down Handrails on 2632E2,  
 2646E2, 3246E2  
 Lubrication-Free Scissor Arm Bushings

## Available Options

Battery Condition Indicator  
 Fold-Down Handrails<sup>1</sup>  
 Spring-Loaded Half Gate<sup>2</sup>  
 Pressure Check Port  
 Flashing Amber Beacon  
 Proportional Control Package  
 Featuring the JLG SMART System<sup>3</sup>  
 QuikWelder™ Package<sup>4</sup>  
 Drywall Gate<sup>5</sup>  
 Horn  
 800W-AC Inverter  
 All Motion Alarm  
 1. Standard on 2632E2, 2646E2, 3246E2.  
 2. Includes Drywall Gate.  
 3. Available only on 2632E2 and 3246E2.  
 4. Not available with Spring-Loaded Gate on 1932E2.  
 5. Standard on 2032E2 w/Fold-Down Handrail Option.

# Built-In Power and Versatility!

JLG lifts provide the strength and power required to meet more of your real-world needs. And now you can transform your Model E2 scissor lift into a truly versatile and productive Workstation in the Sky™ product with exclusive options and accessories from JLG. Whether designed for a specific application or to meet a variety of other jobsite requirements, JLG offers you a competitive advantage with the most versatile solutions.

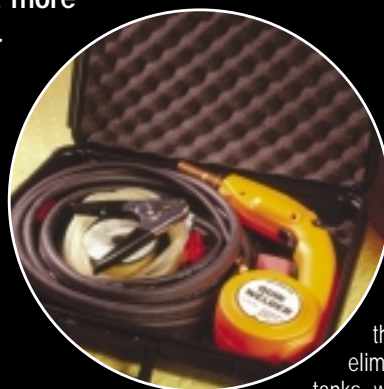

## QuikWelder™ Package

Take welding productivity to new heights with JLG's exclusive on-board QuikWelder Package. Ideal for maintenance and repairs in plants and facilities where spot welding is required, the on-board QuikWelder Package eliminates the need to move bulky tanks, welding units and lead cables from project to project. Just plug it in and go to work. With twice the power of a 110-volt plug-in welder (200 amps of power), the QuikWelder Package can weld light to heavy gauge steel—up to 1/2 in. (1.27 cm) and 3/4 in. (1.9 cm) aluminum.



## Inverter Option

The 800W-AC Inverter Option provides power to the platform to run drills and other hand-held tools. The 800W-AC Inverter is conveniently mounted for access and provides a protective covering to prevent damage.

## Drywall Gate Option

For projects involving bulky items like drywall sheets, equip your JLG Model E2 scissor lift with the Drywall Gate Option. The lock-in-place entry gate allows the loading and unloading of 4-foot-wide drywall sheets that range in length from 8 to 12 feet (1.22 x 3.66m). This option can also handle other large cargo for increased operator jobsite productivity.

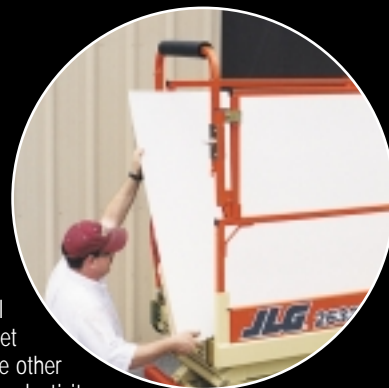

## The JLG "1 & 5" Warranty

JLG Industries, Inc. backs its products with its exclusive "1 & 5" Warranty. We provide coverage on all products for one (1) full year, and cover all specified major structural components for five (5) years. Due to continuous product improvements, we reserve the right to make specification and/or equipment changes without prior notification. This machine meets or exceeds applicable OSHA Regulations in 29 CFR 1910.67, 29 CFR 1926.453, ANSI A92.6-1999, and CSA Standard CAN3-B354.2-M82, as originally manufactured for intended applications.

## JLG Industries, Inc.

1 JLG Drive, McConnellsburg, PA 17233-9533  
Telephone 717-485-5161 Toll-free in US 877-JLG-LIFT  
Fax 717-485-6417  
[www.jlg.com](http://www.jlg.com)

Printed in USA  
FORM NO.: SS-E2-202-10M  
PART NO.: 3131307

