

Parts Manual for
SNAPPER®

**27" 11.5TP INTERMEDIATE TWO STAGE
SNOW THROWER
2010 MODEL**

<i>Model No.</i>	<i>Description</i>
1695908	M1227E

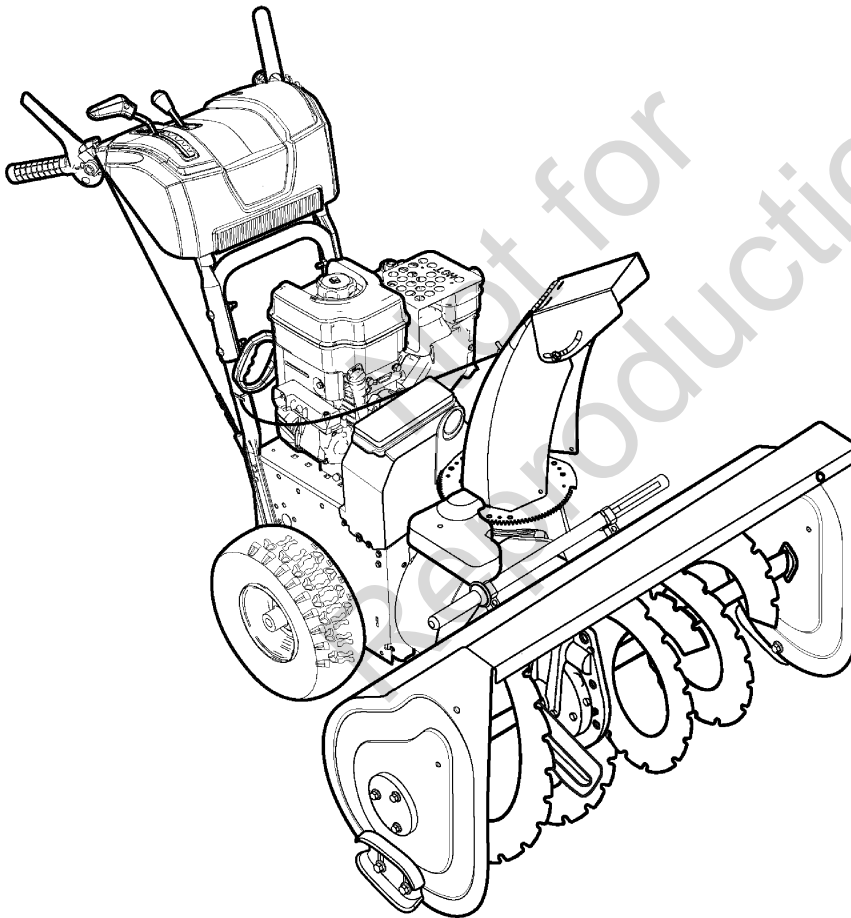

Briggs & Stratton Yard Power Products Group
535 Macon Road
McDonough, GA, 30253 U.S.A.
800-935-2967

Manual No.	1750718
Revision: -	6/2/2010

Not for
Reproduction

PAGE	GROUP
4	Handle & Controls Group
8	Auger Housing Group
10	Auger Drive Group
12	Gear Case Assembly
14	Discharge Chute Group
16	Engine & Frame Group
18	Traction Drive Group - Standard
20	Wheel Group
22	Decals Group

Not for
Reproduction

Handle & Controls Group

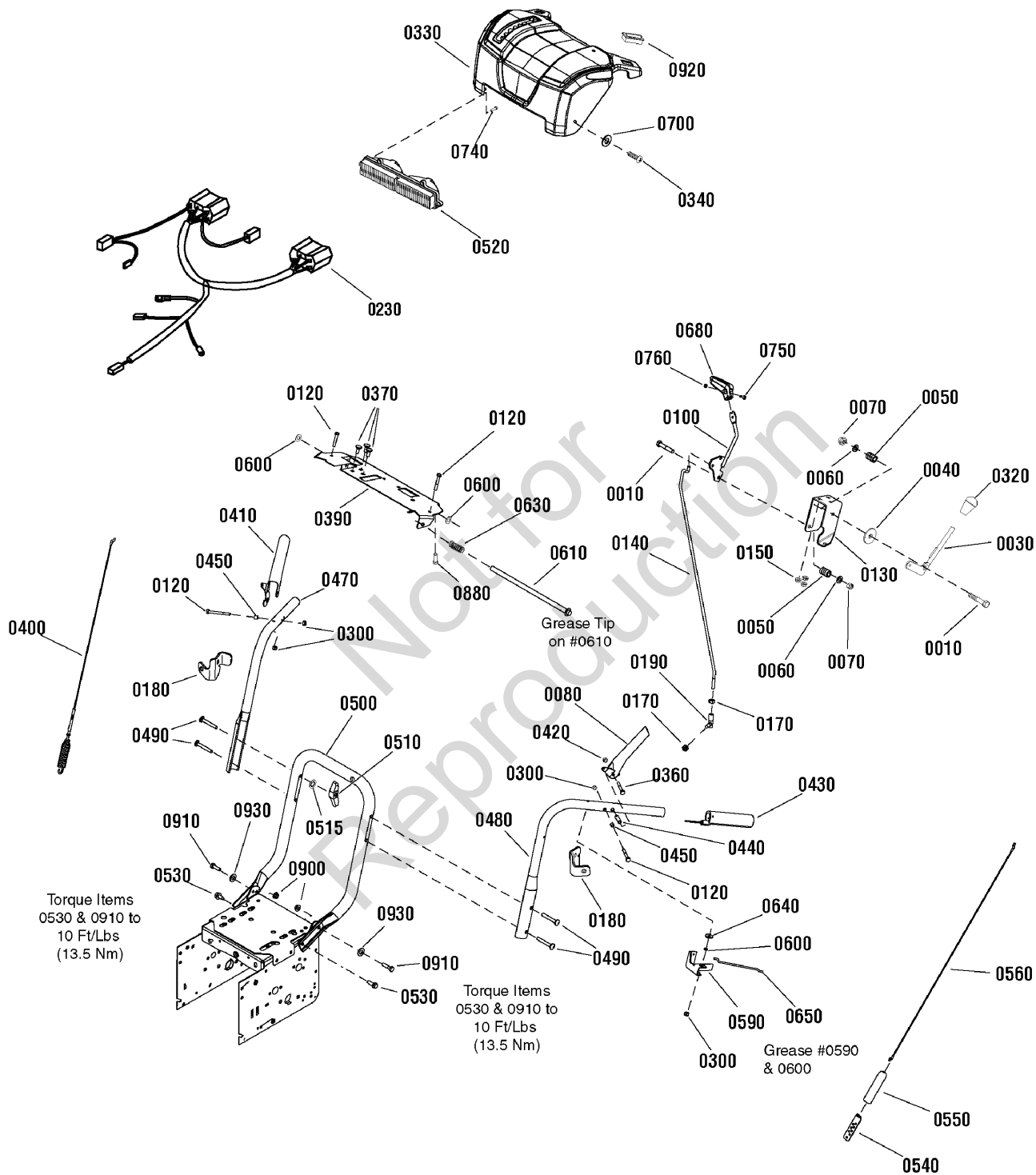

Handle & Controls Group

Item	Part No	Qty	Description
0010	1923701	2	CAPSCREW, Hex Head, 3/8-16 x 2 G5
0030	1736192	1	LEVER, Deflector Control
0040	1924356	1	WASHER, 3/8
0050	724361	2	SPRING
0060	1918266	2	WASHER, 3/8
0070	1919439	2	NUT, Hex Lock, Esna Light, 3/8-16
0080	1737690	1	LEVER, Clutch, Left
0100	1736836	1	SPEED LEVER
0120	1921962	4	CAPSCREW, Hex Head, 1/4-20 x 1-3/4 G5
0130	1737684	1	BRACKET, Controls
0140	1734354	1	ROD, 25.3/8 Long
0150	1931277	3	NUT, Hex Flange, Whiz Lock, 5/16-18
0170	2820263	1	NUT, Hex, 5/16-24
0180	1739487	2	BRACKET, Mounting, Dash
0190	724360	1	BALLJOINT
0230	1738284	1	HARNESS, Wire, Headlights
0300	1920397	4	NUT, Hex Lock, Esna Light, 1/4-20
0320	1732470	1	KNOB, Internal Thread, 3/8-16
0330	1738327	1	DASH ASSEMBLY, Twin Light
0340	1960001	2	SCREW, Hex Washer Head, Plastite, 10-14 x 5/8
0360	1922837	2	CAPSCREW, Hex Head, 1/4-20 x 1-1/2 G5
0370	723873	3	BOLT, Carriage, 5/16-18 x 3/4
0390	1739500A	1	SUPPORT, Dash Panel
0400	1732471	1	ASSEMBLY, Cable & Spring, Right
0410	1736323	1	LEVER, Clutch, Right
0420	1923358	2	NUT, Hex Centerlock, 1/4-20
0430	1726317	2	GRIP
0440	1736542	2	SPACER, Stepped
0450	1678392	2	SPACER, 1/4ID x 3/8OD x 5/16
0470	1734587A	1	HANDLE, Upper, Right
0480	1734586A	1	HANDLE, Upper, Left
0490	1750299	2	BOLT, Carriage, Curved Head, 5/16-18 x 2-1/4
0500	1737759A	1	HANDLE, Lower
0510	7035744	2	KNOB, Wing, 5/16-18
0515	7090391	2	WASHER, Internal Tooth, 5/16
0520	1736176	1	HEADLIGHT ASSEMBLY
0530	1664847	2	SCREW, Hex Washer Head, Taptite, 5/16-18 x 3/4
0540	723259	1	BRACKET, Cable Adjusting

Footnotes:

Handle & Controls Group

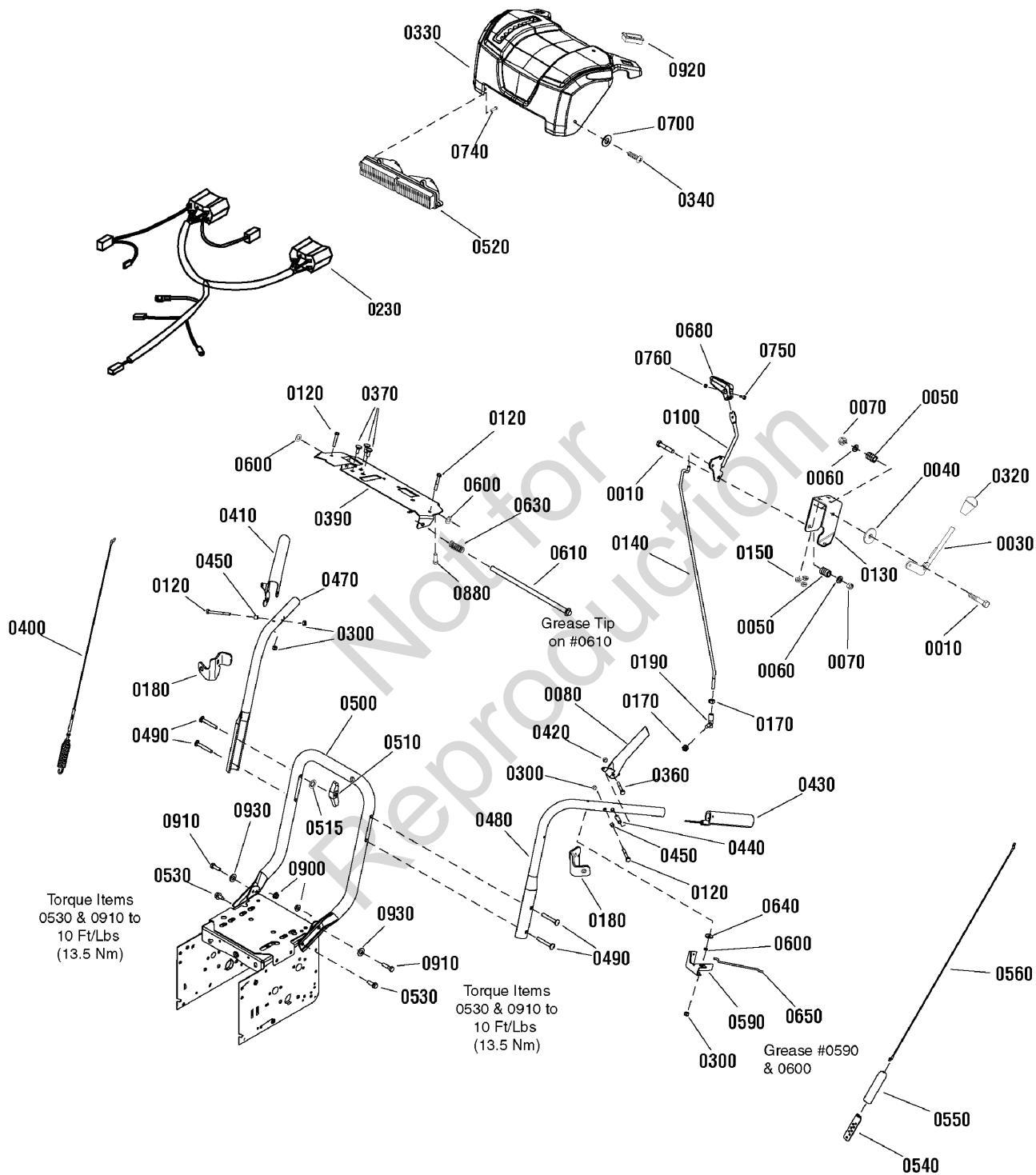

Handle & Controls Group

Item	Part No	Qty	Description
0550	723154	1	BOOT, Spring End Cover
0560	727331	1	CABLE, FR-DR P7 EXT-HDL
0590	1733505A	1	BRACKET, Pivot, Free Hand
0600	1733095	1	SPACER, 1/4ID x 3/8OD x 1/8
0610	1733509	1	ROD & SPRING ASSEMBLY
0630	2108360	1	SPRING, Compression, 2-1/2 Inch
0640	1960353	1	WASHER, 1/4
0650	1736360	1	ROD, 5-1/2 Long
0680	1733192	1	KNOB, Slot Speed
0700	1921319	2	WASHER, 1/4
0740	7091105	4	SCREW, Hex Washer Head, Hi-Lo, #10-16 x 1/2
0750	1960589	1	SCREW, Round Head Phillips, #10-24 x 3/4
0760	7091290	1	NUT, Hex Lock, 10-24
0880	7091081	2	SCREW, Hex Washer Head, Self Tap, 1/4-15 x 3/4
0900	1935048	2	NUT, Hex Flange, Two-Way Lock, 5/16-18
0910	1921333	2	CAPSCREW, Hex Head, 5/16-18 x 1 G5
0920	1709188	1	PLUG
0930	725331	2	WASHER, Flat

Not for
Reproduction

Footnotes:

Auger Housing Group

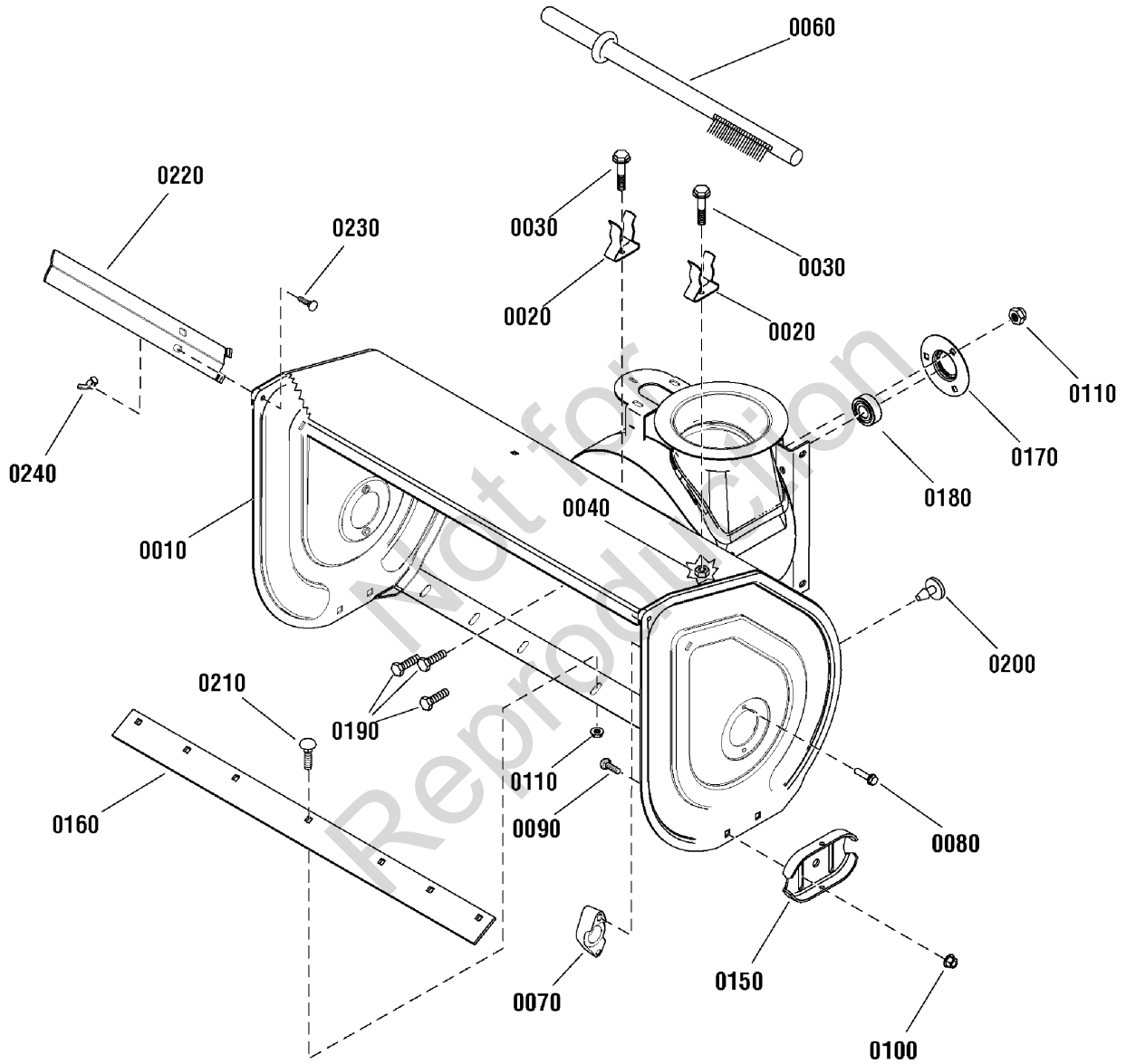

Auger Housing Group

Item	Part No	Qty	Description
0010	1738337D	1	HOUSING
0020	1736620	2	CLIP, Retainer
0030	1960569	2	SCREW, Truss Head Torx, #10-24 x 3/8
0040	722401	2	NUT, Nylock, 10 x 24
0060	1736094	1	BRUSH, Cleanout
0070	724427	2	BEARING, Auger Shaft
0080	722839	4	SCREW, Hex Washer Head, 5/16-18 x 3/4
0090	7091547	4	BOLT, Carriage, 3/8-16 x 3/4 GR5
0100	7091619	4	NUT, Hex Flange, 3/8-16
0110	725273	7	NUT, Hex Flange, Serrated Lock, 5/16-18
0150	1727854A	2	SKID, Shoe Reversible
0160	1740745A	1	BLADE, Scraper
0170	724712	1	RETAINER, Ball Bearing
0180	1705897	1	BEARING, Ball
0190	720018	3	BOLT, Hex, 5/16-18 x 5/8
0200	725521	2	PLUG
0210	7090799	4	BOLT, Carriage, 5/16-18 x 5/8 GR5
0220	1733102A	2	DRIFT CUTTER
0230	723873	2	BOLT, Carriage, 5/16-18 x 3/4
0240	725347	2	NUT, Wing, 5/16-18

Not for
Reproduction

Footnotes:

Auger Drive Group

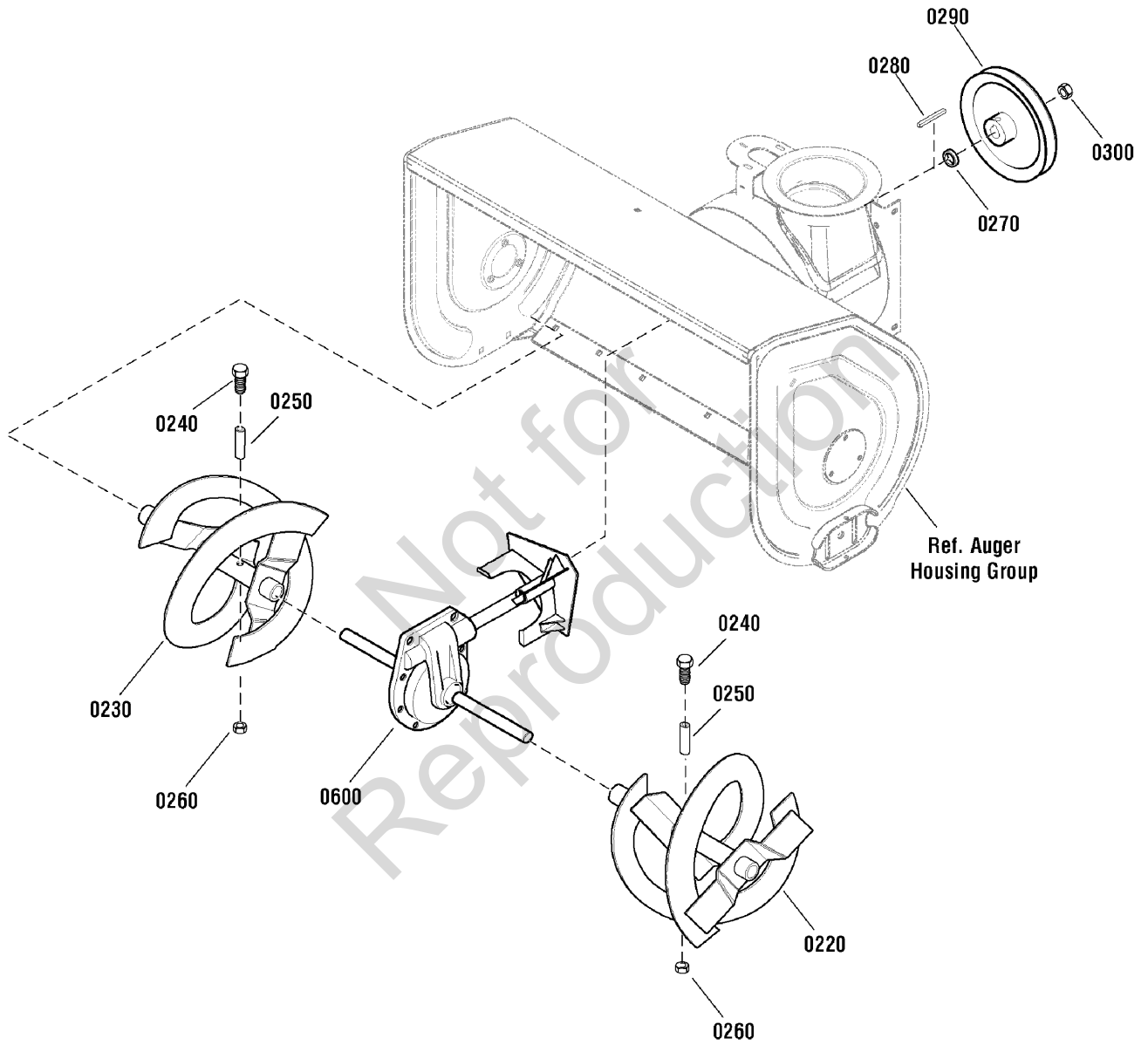

Auger Drive Group

Item	Part No	Qty	Description
0220	1740736A	1	AUGER, Left
0230	1740737A	1	AUGER, Right
0240	726061	2	SCREW, Hex Head, 1/4-20 x 1-3/4 GR 2
0250	723913	2	SPACER, Sleeve
0260	725429	2	NUT, Hex, Centerlock, 1/4-20
0270	722110	1	SPACER, Friction Pulley
0280	722726	1	KEY, Square
0290	724731	1	PULLEY, 4L 8.40 OD
0300	722389	1	NUT, Hex Flange, Serrated Lock, 1/2-20
0600	1739272	1	GEAR CASE ASSEMBLY
--	722130	1	SHEAR BOLT KIT (Includes Ref. Nos. 0240, 0250 & 0260)

Not for
Reproduction

Footnotes:

Gear Case Assembly

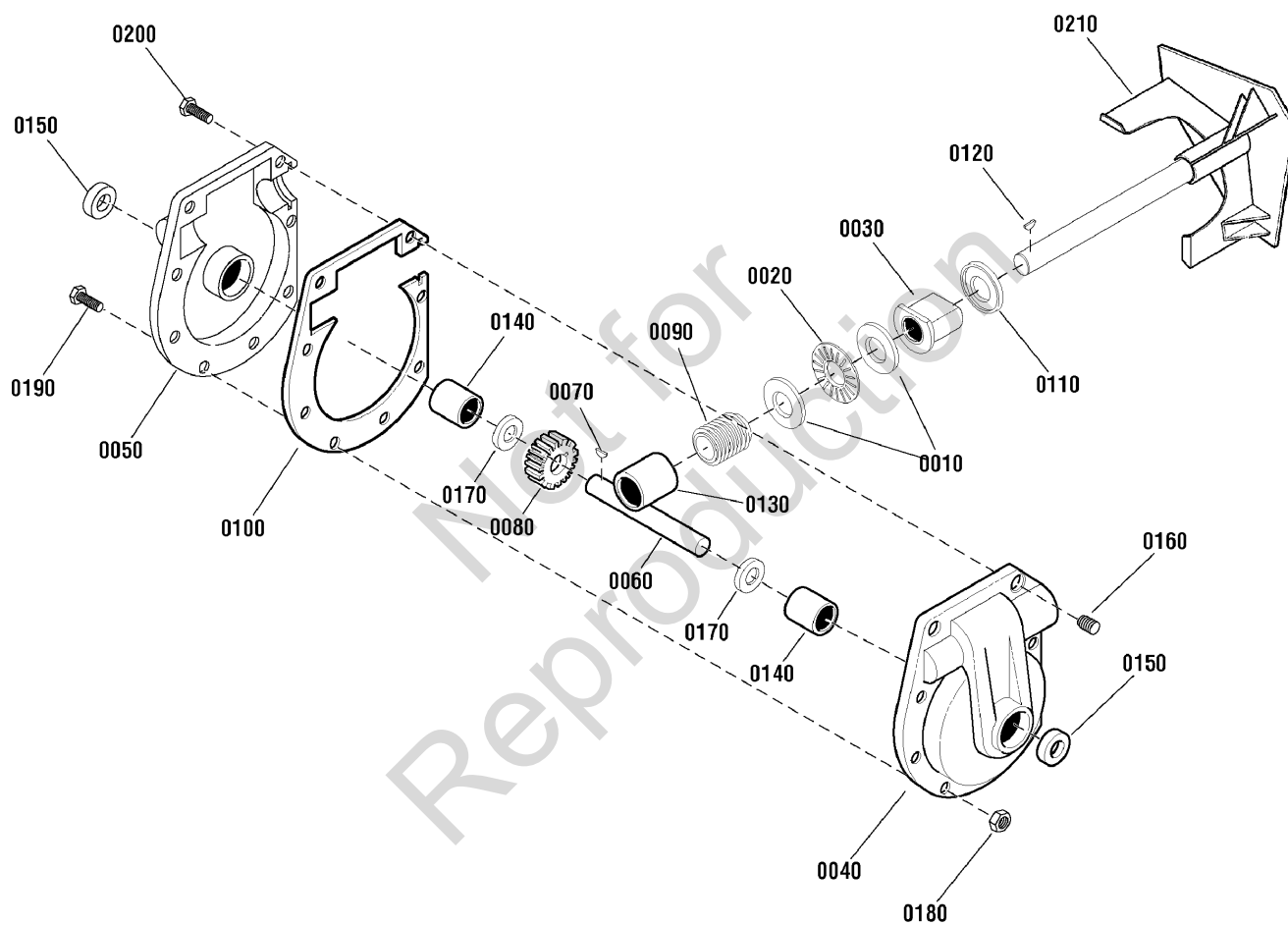

Gear Case Assembly

Item	Part No	Qty	Description
0010	724079	2	WASHER, Thrust
0020	724352	1	BEARING, Roll
0030	724729	1	BREARING, Flange
0040	725981	1	CASE, Gear, Left
0050	725982	1	CASE, Gear, Right
0060	728839	1	SHAFT, Auger Out
0070	725433	1	KEY, Woodruf
0080	724419	1	GEAR, Worm
0090	724421	1	WORMGEAR
0100	725983	1	GASKET, Gear Box
0110	724423	1	RING, Quad
0120	724366	1	KEY, HI-PRO
0130	724420	1	BEARING, Sleeve, 3/4ID x 7/8OD
0140	724424	2	BEARING, Sleeve
0150	725874	2	SEAL, Oil CR 530552
0160	724426	1	PLUG, Pipe
0170	724425	2	WASHER, 1
0180	725338	8	NUT, Hex Flange, Serrated Lock, 5/16-24
0190	725996	7	BOLT, Hex, 5/16-24 x 1
0200	723575	1	SCREW, 5/16-24 x 1-1/2
0210	1740584A	1	IMPELLER

Not for
Reproduction

Footnotes:

Discharge Chute Group

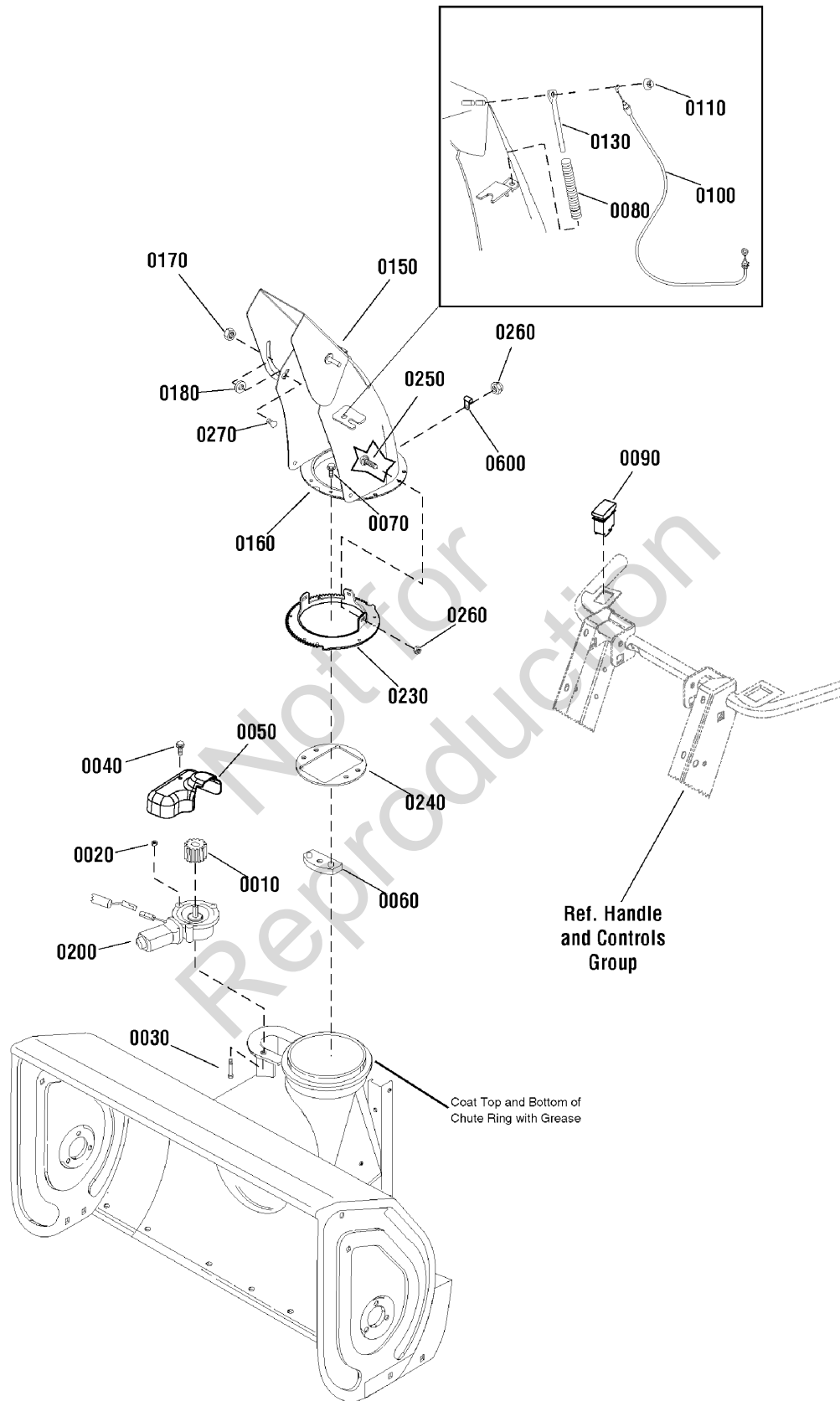

Discharge Chute Group

Item	Part No	Qty	Description
0010	1728967	1	PINION
0020	1960745	3	NUT, Hex Flange, Whiz Lock, #10-24
0030	2860604	3	SCREW, Hex Washer Head,#10C x 1-1/4 G2
0040	1925592	1	SCREW, Hex Washer Head, Taptite, 1/4-20 x 3/4
0050	1737455	1	COVER, Electric Chute Rotation
0060	7011938	3	RETAINER, Spout
0070	1960001	6	SCREW, Hex Washer Head, Plastite, 10-14 x 5/8
0080	1734647	1	SPRING, Compression, 6 Inch
0090	1738243	1	SWITCH, Chute Rotation
0100	1750623	1	CABLE, Delfector Control
0110	1932718	1	NUT, Push, 5/16
0130	1734708A	1	ROD, Spring Guide, 5-7/8
0150	1738340	2	DECAL, Chute Hinge
0160	1737443D	1	CHUTE
0170	1960686	1	NUT, Hex Flange, ESNA, 5/16-18
0190	1931333	1	BOLT, Carriage, 5/16-18 x 3/4 G5
0200	1728965	1	MOTOR, Spout Rotator
0230	1737465A	1	GEAR, Short, Steel Chute
0240	1737411	1	ADAPTER, Chute Ring
0250	1931317	7	BOLT, Carriage, 1/4-20 x 3/4 G5
0260	2860694	7	NUT, Hex Flange, Esna, 1/4-20
0270	2860210	2	WASHER, Nylon, 3/8
0600	1739331	1	CLIP, Cable

Not for
Reproduction

Footnotes:

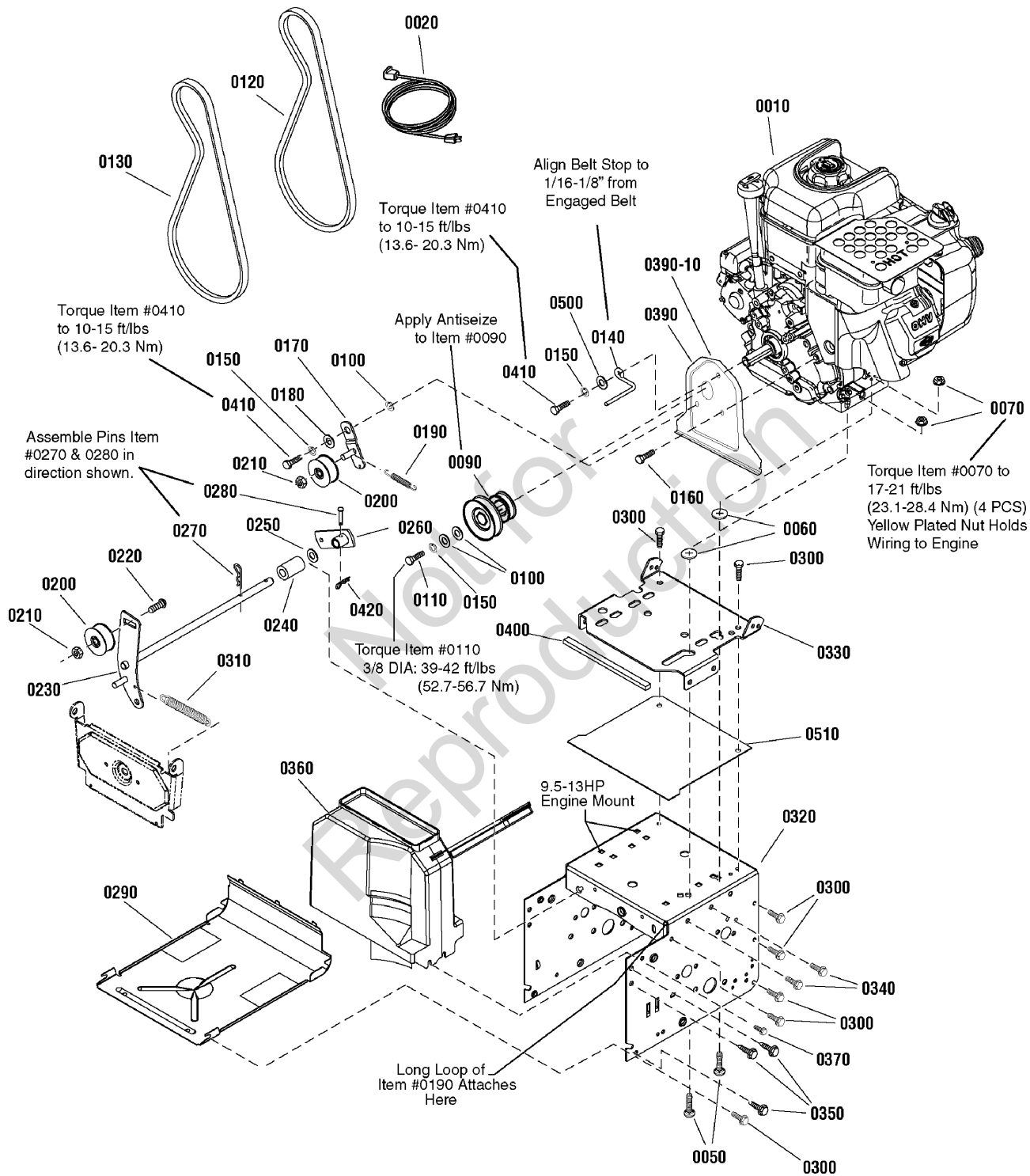

Engine & Frame Group

Item	Part No	Qty	Description
0010	15C114-0131-E8	1	* ENGINE, 11.5TP, B&S (Engine Model: 15C114-0131-E8)
0020	724865	1	CORD, Starter
0050	720064	4	BOLT, Carriage, 5/16-18 x 1-1/2
0060	720376	4	NUT, Push
0070	1739305	4	NUT, Hex Flange, ESNA, 5/16-18
0090	722085	1	PULLEY, Engine
0100	1919381	3	WASHER, 5/16
0110	1921982	1	CAPSCREW, Hex Head, 5/16-24 x 1-1/4 G5
0120	1733324	1	V-BELT, Drive, 3L, 33.13
0130	724801	1	BELT, Auger, V4L 38.10
0140	1739070	1	BELT GUIDE
0150	1917356	3	LOCKWASHER, Spring, 5/16
0160	1921515	1	CAPSCREW, Hex Head, 5/16-24 x 3/4, G5
0170	722090	1	BRACKET, Idler
0180	722072	1	BUSHING, Idler Bracket
0190	724418	1	SPRING, Extension Idler
0200	722378	2	IDLER
0210	1960251	2	NUT, Hex Centerlock Jaam, 3/8-16
0220	724823	1	BOLT, Carriage, 3/8-16X x 1-1/4 G5
0230	722132	1	AUGER IDLER
0240	722118	1	SPACER, 1/2ID x 1OD x 1-3/4
0250	1960027	1	WASHER, 1/2
0260	1733451	1	ARM, Control
0270	725367	1	PIN, Hair
0280	1736381	1	PIN, Clevis
0290	1740906A	1	PANEL, Bottom
0300	1927429	12	SCREW, Hex Washer Head, Taptite, 1/4-20 x 5/8
0310	722455	1	SPRING, Extension Auger
0320	1740572D	1	FRAME BOX
0330	1733583D	1	PLATE, Engine Mount
0340	1924856	4	SCREW, Hex Washer Head, Taptite, 5/16-18 x 1/2
0350	1664847	6	SCREW, Hex Washer Head, Taptite, 5/16-18 x 3/4
0360	1733923	1	COVER
0370	722887	2	Screw, Self Tapping, 1/4 x 3/4
0390	1733868A	1	WATER SHIELD
0390-10	1733898	1	SEAL, Foam
0400	1750172	1	STRIP, Seal
0410	725996	1	BOLT, Hex, 5/16-24 x 1
0420	7023590	1	COTTER PIN, 1/4
0500	7091528	1	WASHER, Flat, 3/8
0510	1750135	1	SEAL, Engine Plate

Footnotes:

Note* See your local Briggs & Stratton Distributor for Parts & Service.

Traction Drive Group - Standard

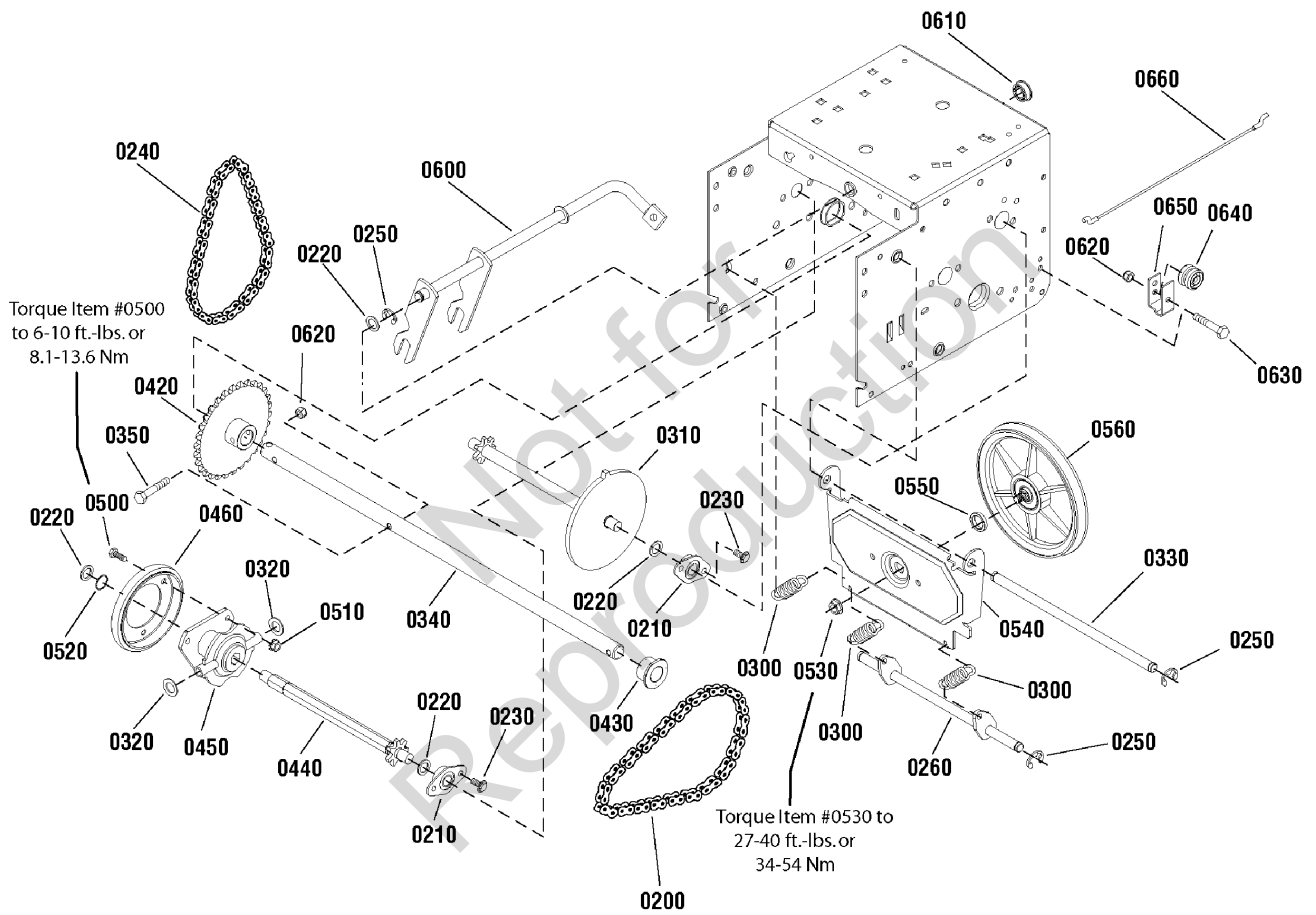

Traction Drive Group - Standard

Item	Part No	Qty	Description
0200	724613	1	CHAIN, Roller, 19"
0210	723655	4	RETAINER & BUSHING ASSEMBLY
0220	724619	5	WASHER, Flat, 1/2
0230	1924856	8	SCREW, Hex Washer Head, Taptite, 5/16-18 x 1/2
0240	724627	1	CHAIN, Roller, 18 Inch
0250	721910	5	RETAINER, Ring, 7/16
0260	722377	1	SPRING LINK
0300	1736469	3	SPRING, Extension
0310	722081	1	SPROCKET
0320	1960027	2	WASHER, 1/2
0330	722082	1	AXLE, Swing Plate
0340	722211	1	AXLE, 23-1/8 Lg
0350	720220	1	BOLT, Hex, 1/4-20 x 1-3/4, G8
0420	722080	1	AXLE SPROCKET, 30T
0430	722091	2	BEARING, Axle, D-Hole
0440	722083	1	HEX SHAFT & SPROCKET ASSEMBLY
0450	723694	1	HUB, Friction Wheel and Bearing
0460	722185	1	WHEEL, Friction
0500	1921959	3	CAPSCREW, Hex Head, 1/4-20 x 5/8 G5
0510	1928372	3	NUT, Hex Keps, 1/4-20
0520	1733326	1	RING, Retaining
0530	722391	1	NUT, Flange Lock, 3/8-24
0540	722069	1	PLATE, Swinging
0550	722110	1	SPACER, Friction Pulley
0560	722092	1	FRICITION PULLEY ASSEMBLY
0600	722087	1	SPEED SELECTOR ASSEMBLY
0610	724636	1	BEARING, Flange, 1/2ID x 7/8OD
0620	1920397	2	NUT, Hex Lock, ESNA Light, 1/4-20
0630	1922837	1	CAPSCREW, Hex Head, 1/4-20 x 1-1/2 G5
0640	724621	1	CABLE SPOOL, Auger Control
0650	722070	1	BRACKET, Cable Spool
0660	722095	1	CABLE, Front Lower Drive

Footnotes:

Wheel Group

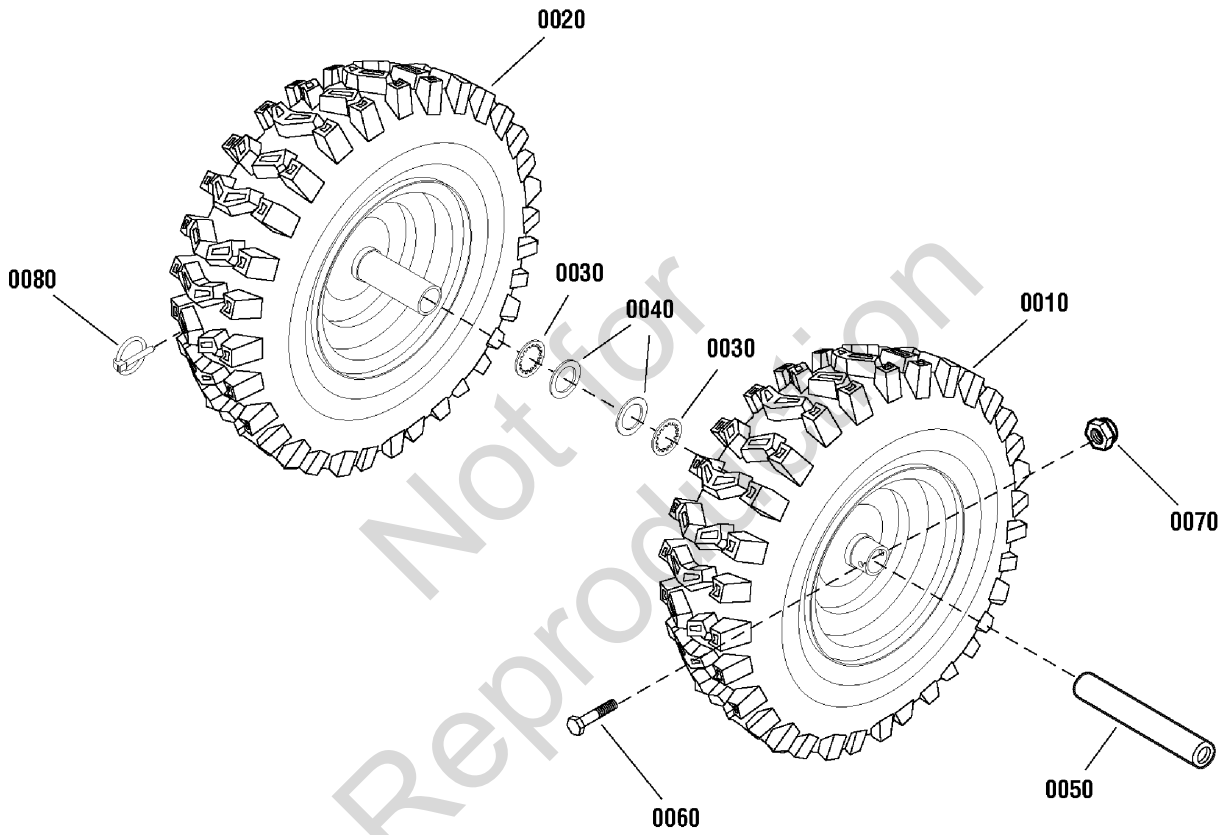

Wheel Group

Item	Part No	Qty	Description
0010	1736779	1	WHEEL ASSEMBLY, 8X4.8 P2-539, Left
--	7012234	1	VALVE, Stem & Cap (Not shown) or 2172353
--	2164247	1	TUBE, Tire 16 x 6 1/2-8 (Not shown)
0020	1736778	1	WHEEL ASSEMBLY, 8X4.8 P2-539, Right
0030	1657528	2	RETAINING RING
0040	725394	2	WASHER, Flat, 3/4
0050	722102	2	BUSHING, Wheel
0060	724545	1	BOLT, HEX, 1/4-20 x 3/4, G5
0070	722400	1	NUT, Hex, Nylock, 1/4-20
0080	725431	1	PIN, Klik

Not for
Reproduction

Footnotes:

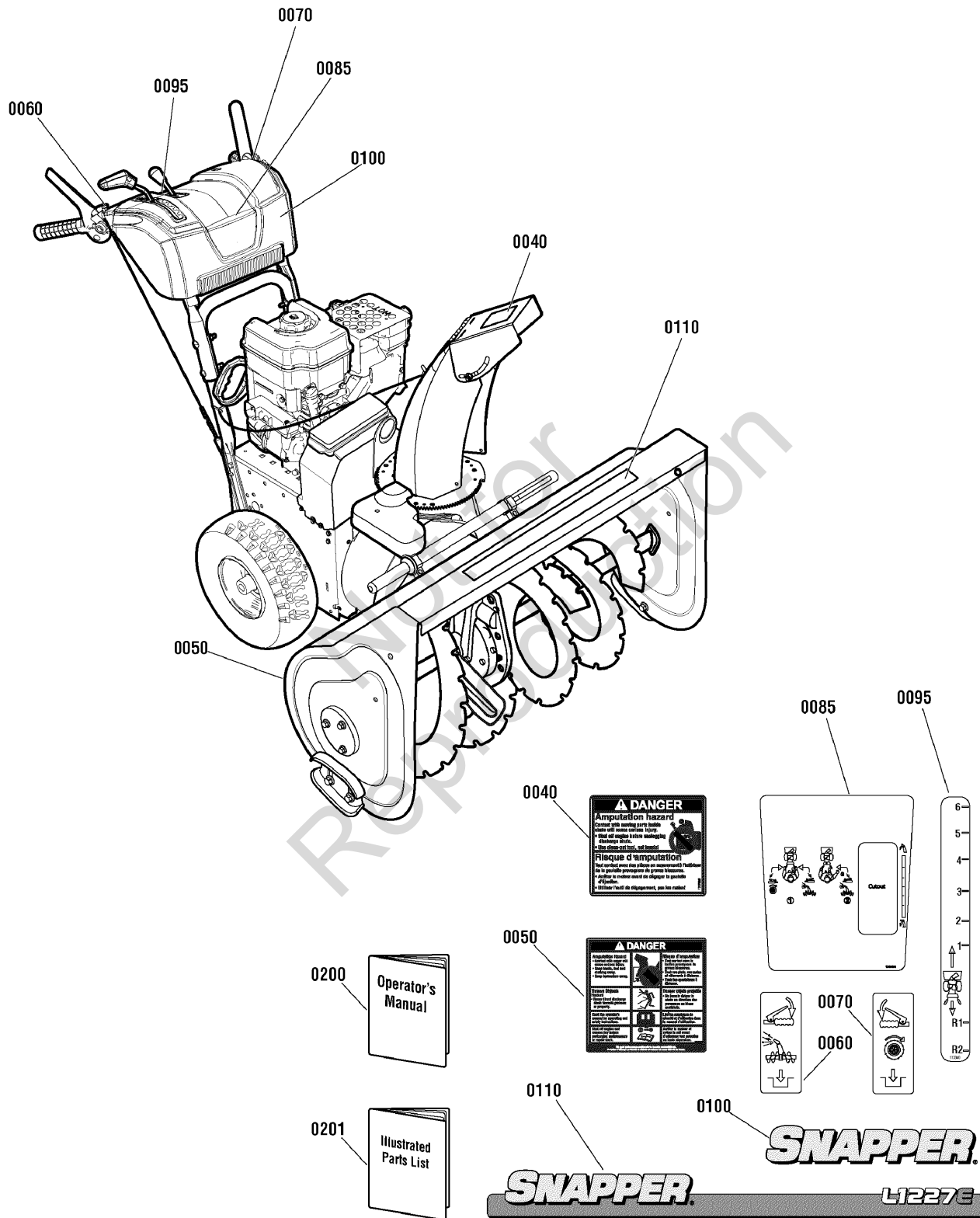

▲ DANGER
Amputation hazard
 Contact with moving parts, blades, wheels or other sharp edges can cause serious injury or death.
Risque d'amputation
 Le contact avec les parties en mouvement, les lames, les roues et les autres parties tranchantes peut causer des blessures graves ou la mort.

▲ DANGER
 Amputation hazard
 Contact with moving parts, blades, wheels or other sharp edges can cause serious injury or death.
Risque d'amputation
 Le contact avec les parties en mouvement, les lames, les roues et les autres parties tranchantes peut causer des blessures graves ou la mort.

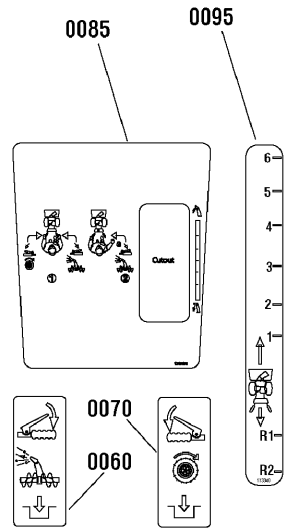

0200 Operator's Manual

0201 Illustrated Parts List

SNAPPER
L1227E

Decals Group

Item	Part No	Qty	Description
0040	1737865	1	DECAL, Danger Chute, FR/ENG
0050	1737866	1	DECAL, Danger Foot, FR/ENG
0060	1737869	1	DECAL, Auger Control Symbols
0070	1737870	1	DECAL, Traction Control
0085	1737875	1	DECAL, Controls, With Remote
0095	1738349	1	DECAL, Speed Control
0100	1750407	1	DECAL, Logo
0110	1750409	1	DECAL, Auger Housing
0200	1750337	1	MANUAL, Operators
0201	1750718	1	MANUAL, Illustrated Parts List

Not for
Reproduction

Footnotes:

Hardware Identification & Torque Specifications

Torque Specification Chart								
FOR STANDARD METRIC MACHINE HARDWARE (Tolerance ± 20%)								
Property Class	5.6		8.8		10.9		12.9	
	Class 5.6		Class 8.8		Class 10.9		Class 12.9	
Size Of Hardware	in/lbs		in/lbs		in/lbs		in/lbs	
	ft/lbs	Nm.	ft/lbs	Nm.	ft/lbs	Nm.	ft/lbs	Nm.
M3	5.88	.56	13.44	1.28	19.2	1.80	22.92	2.15
M4	13.44	1.28	30.72	2.90	43.44	4.10	52.56	4.95
M5	26.4	2.50	60.96	5.75	5.97	8.10	7.15	9.7
M6	44.64	4.3	7.3	9.9	10.3	14	12.1	16.5
M7	5.2	7.1	12.1	16.5	16.9	23	19.9	27
M8	7.7	10.5	17.7	24	25	34	29	40
M10	15	21	35	48	50	67	59	81
M12	26	36	61	83	86.2	117	103	140
M14	42	58	101	132	136	185	162	220
M16	64	88	147	200	210	285	250	340
M18	89	121	202	275	287	390	346	470
M20	126	171	290	390	405	550	486	660
M22	169	230	390	530	559	745	656	890
M24	217	295	497	375	708	960	840	1140
M27	320	435	733	995	1032	1400	1239	1680
M30	435	590	995	1350	1401	1900	1681	2280
M33	590	800	1349	1830	1902	2580	2278	3090
M36	759	1030	1740	2360	2441	3310	2935	3980
M39	988	1340	2249	3050	3163	4290	3798	5150

Torque Specification Chart						
FOR STANDARD MACHINE HARDWARE (Tolerance ± 20%)						
Hardware Grade	No Marks		SAE Grade 5		SAE Grade 8	
	SAE Grade 2		SAE Grade 5		SAE Grade 8	
Size Of Hardware	in/lbs		in/lbs		in/lbs	
	ft/lbs	Nm.	ft/lbs	Nm.	ft/lbs	Nm.
8-32	19	2.1	30	3.4	41	4.6
8-36	20	2.3	31	3.5	43	4.9
10-24	27	3.1	43	4.9	60	6.8
10-32	31	3.5	49	5.5	68	7.7
1/4-20	66	7.6	8	10.9	12	16.3
1/4-28	76	8.6	10	13.6	14	19.0
5/16-18	11	15.0	17	23.1	25	34.0
5/16-24	12	16.3	19	25.8	29	34.0
3/8-16	20	27.2	30	40.8	45	61.2
3/8-24	23	31.3	35	47.6	50	68.0
7/16-14	30	40.8	50	68.0	70	95.2
7/16-20	35	47.6	55	74.8	80	108.8
1/2-13	50	68.0	75	102.0	110	149.6
1/2-20	55	74.8	90	122.4	120	163.2
9/16-12	65	88.4	110	149.6	150	204.0
9/16-18	75	102.0	120	163.2	170	231.2
5/8-11	90	122.4	150	204.0	220	299.2
5/8-18	100	136	180	244.8	240	326.4
3/4-10	160	217.6	260	353.6	386	525.0
3/4-16	180	244.8	300	408.0	420	571.2
7/8-9	140	190.4	400	544.0	600	816.0
7/8-14	155	210.8	440	598.4	660	897.6
1-8	220	299.2	580	788.8	900	1,244.0
1-12	240	326.4	640	870.4	1,000	1,360.0

The guides and ruler furnished below are designed to help you select the appropriate hardware.



Nut, M8

Thread Diameter (mm)
Inside Diameter (in) Threads per inch

Nut, 1/2-16

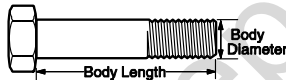

Screw, M8- 1.25 x 25

Thread Diameter (mm) Distance between threads (mm) Body Length (mm)
Body Diameter Threads per inch Body Length (in)

Screw, 1/2- 16 x 2

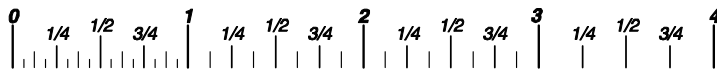

Standard Hardware Sizing

When a washer or nut is identified as 1/2" (M8), this is the *Nominal size*, meaning the *inside diameter* is 1/2 inch (8mm metric thread diameter); if a second number is present it represents the *threads per inch* (distance between threads).

When bolt or capscrew is identified as 1/2 - 16 x 2" (M8 - 1.25 x 50), this means the *Nominal size*, or body diameter is 1/2 inch (8mm metric thread diameter), the second number, 16, represents the *threads per inch*, (1.25 thread diameter). The final number is the body length of the bolt or screw, 2 inches (50mm).

NOTES

- These torque values are to be used for all hardware excluding: locknuts, self-tapping screws, thread forming screws, sheet metal screws and socket head setscrews.
- Recommended seating torque values for locknuts:
 - for prevailing torque locknuts - use 65% of grade 5 torques.
 - for flange whizlock nuts and screws - use 135% of grade 5 torques.
- Unless otherwise noted on assembly drawings, all torque values must meet this specification.

Common Hardware Types

Hex Head Capscrew



Washer



Lockwasher



Carriage Bolt



Hex Nut



Wrench & Fastener Size Guide

1/4" Bolt or Nut Wrench—7/16"	5/16" Bolt or Nut Wrench—1/2"	3/8" Bolt or Nut Wrench—9/16"	7/16" Bolt or Nut Wrench (Bolt)—5/8" Wrench (Nut)—11/16"	1/2" Bolt or Nut Wrench—3/4"
M6 Bolt or Nut Wrench—10mm	M8 Bolt or Nut Wrench—13mm	M10 Bolt or Nut Wrench—17mm	M12 Bolt or Nut Wrench—19mm	M14 Bolt or Nut Wrench—22mm

Parts Manual for

SNAPPER®

27" 11.5TP INTERMEDIATE TWO STAGE SNOW THROWER 2010 MODEL

Not for
Reproduction

IT IS THE POLICY OF BRIGGS & STRATTON CORP TO IMPROVE ITS PRODUCTS WHENEVER IT IS POSSIBLE AND PRACTICAL TO DO SO. WE RESERVE THE RIGHT TO MAKE CHANGES OR ADD IMPROVEMENTS AT ANY TIME WITHOUT INCURRING ANY OBLIGATION TO MAKE SUCH CHANGES ON PRODUCTS

Briggs & Stratton Yard Power Products Group

535 Macon Road
McDonough, GA, 30253 U.S.A.
800-935-2967

www.snapper.com

Copyright © 2010 Briggs & Stratton Corporation
Milwaukee, WI USA. All Rights Reserved

Manual No. 1750718

Revision: - 6/2/2010