

www.wackergroup.com

0154614en	006
0308	

Pump

PDT 2A

PDI 2A

PDT 3A

PDI 3A

OPERATOR'S MANUAL



0 1 5 4 6 1 4 E N

1. Foreword	5
2. Safety Information	6
2.1 Laws Pertaining to Spark Arresters	6
2.2 Operating Safety	8
2.3 Operator Safety while using Internal Combustion Engines	9
2.4 Service Safety	9
2.5 Label Locations	10
2.6 Safety Labels	11
3. Technical Data	13
3.1 Engine	13
3.2 Pump	14
3.3 Sound Measurements	15
3.4 Dimensions	16
4. Operation	18
4.1 Application	18
4.2 Recommended Fuel	18
4.3 Transporting the Machine	19
4.4 Priming Pump	20
4.5 Before Starting	20
4.6 To Start	21
4.7 To Stop	21
4.8 Operation	22
4.9 Accessories	22
4.10 Hoses and Clamps	23
5. Maintenance	24
5.1 Periodic Maintenance Schedule	24
5.2 Changing Engine Oil	25
5.3 Servicing Air Cleaner	26

5.4	Spark Plug	27
5.5	Gear Case	28
5.6	Connecting Rod Bearing	29
5.7	Cleaning Pump	29
5.8	Cleaning Sediment Cup	30
5.9	Carburetor Adjustment	30
5.10	Storage	31
5.11	Troubleshooting	32
5.12	Decommissioning	33

CALIFORNIA

Proposition 65 Warning:



Engine exhaust, some of its constituents, and certain vehicle components, contain or emit chemicals known to the State of California to cause cancer and birth defects or other reproductive harm.

1 Foreword

This manual provides information and procedures to safely operate and maintain this Wacker model. For your own safety and protection from injury, carefully read, understand and observe the safety instructions described in this manual.

Keep this manual or a copy of it with the machine. If you lose this manual or need an additional copy, please contact Wacker Corporation. This machine is built with user safety in mind; however, it can present hazards if improperly operated and serviced. Follow operating instructions carefully! If you have questions about operating or servicing this equipment, please contact Wacker Corporation.

The information contained in this manual was based on machines in production at the time of publication. Wacker Corporation reserves the right to change any portion of this information without notice.

All rights, especially copying and distribution rights, are reserved.

Copyright 2008 by Wacker Corporation.

No part of this publication may be reproduced in any form or by any means, electronic or mechanical, including photocopying, without express written permission from Wacker Corporation.

Any type of reproduction or distribution not authorized by Wacker Corporation represents an infringement of valid copyrights and will be prosecuted. We expressly reserve the right to make technical modifications, even without due notice, which aim at improving our machines or their safety standards.

2. Safety Information

This manual contains DANGER, WARNING, CAUTION, *NOTICE* and NOTE callouts which must be followed to reduce the possibility of personal injury, damage to the equipment, or improper service.



This is the safety alert symbol. It is used to alert you to potential personal injury hazards. Obey all safety messages that follow this symbol to avoid possible injury or death.



DANGER

DANGER indicates a hazardous situation which, if not avoided, will result in death or serious injury.



WARNING

WARNING indicates a hazardous situation which, if not avoided, could result in death or serious injury.



CAUTION

CAUTION indicates a hazardous situation which, if not avoided, could result in minor or moderate injury.

NOTICE: Used without the safety alert symbol, **NOTICE** indicates a hazardous situation which, if not avoided, could result in property damage.

Note: *Contains additional information important to a procedure.*

2.1 Laws Pertaining to Spark Arresters

Notice: State Health Safety Codes and Public Resources Codes specify that in certain locations spark arresters be used on internal combustion engines that use hydrocarbon fuels. A spark arrester is a device designed to prevent accidental discharge of sparks or flames from the engine exhaust. Spark arresters are qualified and rated by the United States Forest Service for this purpose.

In order to comply with local laws regarding spark arresters, consult the engine distributor or the local Health and Safety Administrator.

2.2 Operating Safety



DANGER

Internal combustion engines present special hazards during operation and fueling. Read and follow the warning instructions in the engine Owner's Manual and the safety guidelines below. Failure to follow the warnings and safety standards could result in severe injury or death.

- 2.2.1 NEVER allow anyone to operate this equipment without proper training. People operating this equipment must be familiar with the risks and hazards associated with it.
- 2.2.2 NEVER touch the engine or muffler while the engine is on or immediately after it has been turned off. These areas get hot and may cause burns.
- 2.2.3 NEVER use accessories or attachments that are not recommended by Wacker. Damage to equipment and injury to the user may result.
- 2.2.4 NEVER pump volatile, flammable or low flash point fluids. These fluids could ignite or explode.
- 2.2.5 NEVER pump corrosive chemicals or water containing toxic substances. These fluids could create serious health and environmental hazards. Contact local authorities for assistance.
- 2.2.6 ALWAYS read, understand, and follow procedures in the Operator's Manual before attempting to operate the machine.
- 2.2.7 ALWAYS be sure operator is familiar with proper safety precautions and operation techniques before using machine.
- 2.2.8 ALWAYS be sure the rammer will not tip over, roll, slide, or fall when not being operated.
- 2.2.9 ALWAYS close fuel valve on engines equipped with one when machine is not being operated.
- 2.2.10 ALWAYS store the machine properly when it is not being used. The machine should be stored in a clean, dry location out of the reach of children.

2.3 Operator Safety while using Internal Combustion Engines



WARNING

A poorly maintained machine can become a safety hazard! In order for the machine to operate safely and properly over a long period of time, periodic maintenance and occasional repairs are necessary.

- 2.3.1 DO NOT smoke while operating the machine.
- 2.3.2 DO NOT smoke when refueling the engine.
- 2.3.3 DO NOT refuel a hot or running engine.
- 2.3.4 DO NOT refuel the engine near an open flame.
- 2.3.5 DO NOT spill fuel when refueling the engine.
- 2.3.6 DO NOT run the engine near open flames.
- 2.3.7 ALWAYS refill the fuel tank in a well-ventilated area.
- 2.3.8 ALWAYS replace the fuel tank cap after refueling.

2.4 Service Safety



WARNING

A poorly maintained machine can become a safety hazard! In order for the machine to operate safely and properly over a long period of time, periodic maintenance and occasional repairs are necessary.



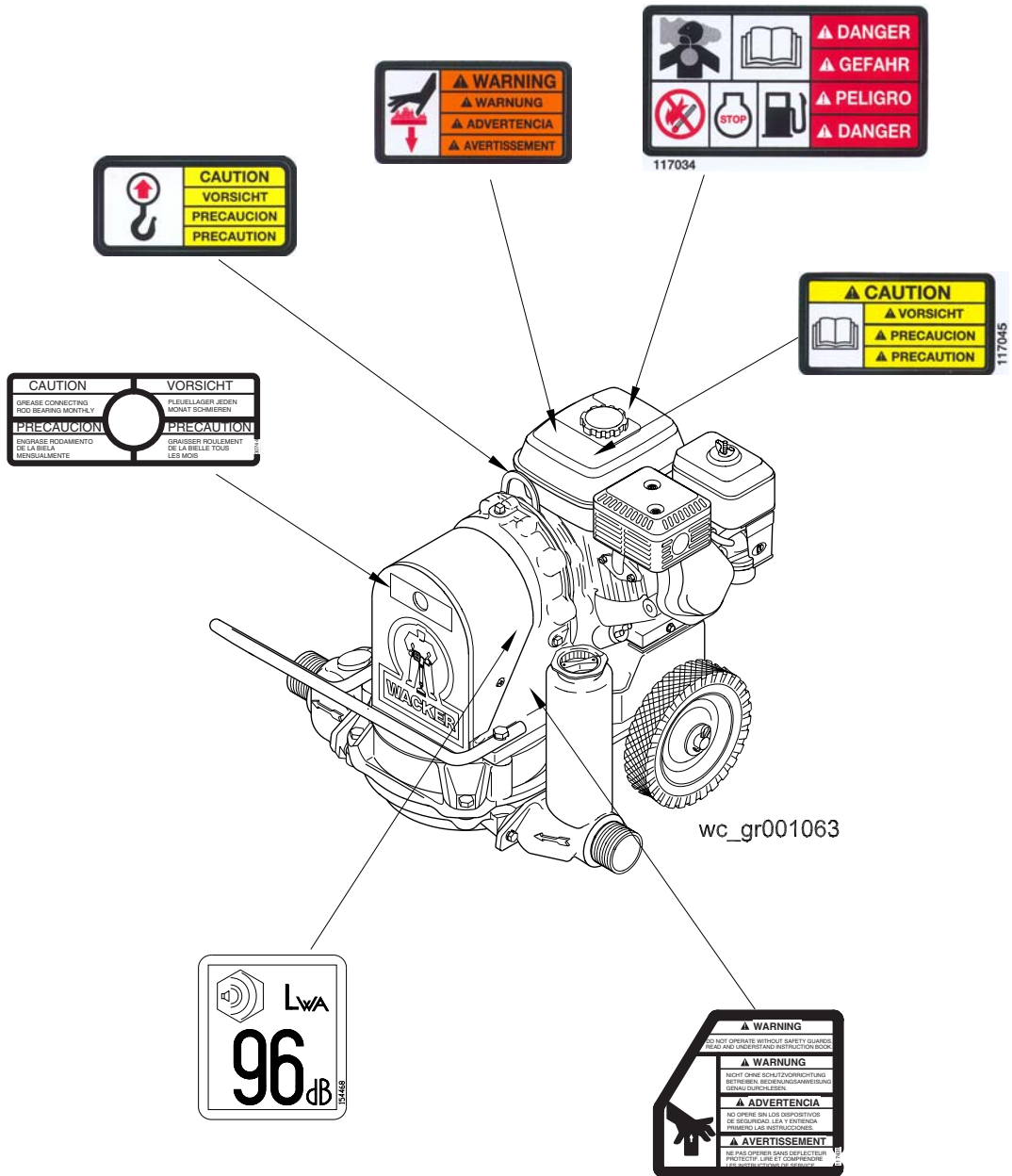

- 2.4.1 DO NOT attempt to clean or service the machine while it is running. Rotating parts can cause severe injury.
- 2.4.2 DO NOT crank a flooded engine with the spark plug removed on gasoline-powered engines. Fuel trapped in the cylinder will squirt out the spark plug opening.
- 2.4.3 DO NOT test for spark on gasoline-powered engines if the engine is flooded or the smell of gasoline is present. A stray spark could ignite the fumes.
- 2.4.4 DO NOT use gasoline or other types of fuels or flammable solvents to clean parts, especially in enclosed areas. Fumes from fuels and solvents can become explosive.
- 2.4.5 ALWAYS operate the machine with all safety devices and guards in place and in working order.
- 2.4.6 ALWAYS keep the area around the muffler free of debris such as leaves, paper, cartons, etc. A hot muffler could ignite the debris and start a fire.
- 2.4.7 ALWAYS replace worn or damaged components with spare parts designed and recommended by Wacker Corporation.
- 2.4.8 ALWAYS disconnect the spark plug on machines equipped with gasoline engines, before servicing, to avoid accidental start-up.



2.5 Label Locations

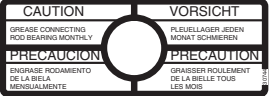

2.6 Safety Labels

Wacker machines use international pictorial labels where needed. These labels are described below:

Label	Meaning
	<p>DANGER! Engines emit carbon monoxide; operate only in well-ventilated area. Read the Operator's Manual. No sparks, flames, or burning objects near the machine. Shut off the engine before refueling.</p>
	<p>WARNING! Hot surface!</p>
	<p>CAUTION! Read and understand the supplied Operator's Manuals before operating this machine. Failure to do so increases the risk of injury to yourself or others.</p>
	<p>WARNING! Pinch point! Do not operate without safety guards. Read and understand the operator's manual.</p>
	<p>CAUTION! Grease connecting rod bearing monthly.</p>

Label	Meaning
	<p>CAUTION! Lifting point.</p>
	<p>Guaranteed sound power level in dB(A).</p>

3. Technical Data

3.1 Engine

Item Number:	PDT/PDI 2A 0007610, 0007611 0007624, 0007625	PDT/PDI 3A 0007614, 0007615, 0007616, 0007628, 0007629, 0009407
Engine		
Engine Make	Honda	
Engine Model	GX 120 K1 QX	
Rated Power	kW (Hp)	3.0 (4.0)
Spark Plug	type	(NGK) BPR 6ES, BOSCH WR 7DC
Electrode Gap	mm (in.)	0.7 – 0.8 (0.028 – 0.031)
Engine speed	rpm	2700 ± 100
Air Cleaner	type	Dual element
Engine Lubrication	oil grade	SAE10W30 - service class SF, SE, SD, or SC
Engine Oil Capacity	ml (oz.)	600 (20)
Fuel	type	Regular unleaded gasoline
Fuel Tank Capacity	l (qts.)	2.5 (2.6)

3.2 Pump

Item Number:		PDT/PDI 2A 0007610, 0007611 0007624, 0007625	PDT/PDI 3A 0007614, 0007615, 0007616, 0007628, 0007629, 0009407
Pump			
Weight	kg (lbs.)	52 (114)	63 (138)
*Max. Suction Lift	m (ft.)	7.5 (25)	7.5 (25)
Max. Discharge Head	m (ft.)	7.5 (25)	7.5 (25)
Max. Total Head	m (ft.)	15 (50)	15 (50)
Max. Discharge Pressure	kg/cm ² (psi)	0.76 (10.8)	0.76 (10.8)
Max. Discharge Flow	m ³ h (gpm)	11 (50)	20 (88)
Gear Case Lubrication	oil grade ml (oz.)	SAE 30 1000 (32)	SAE 30 1000 (32)
Suction / Discharge Dia.	mm (in.)	50 (2)	75 (3)
Maximum Solid Size	mm (in.)	30 (1.25)	45 (1.75)
Ambient air temperature limits	°C (°F)	-17 to 40 (0 to 105)	-17 to 40 (0 to 105)
Pumped fluid temperature limits	°C (°F)	-17 to 65 (0 to 150)	-17 to 65 (0 to 150)

* Based on pump operating at sea level. Maximum suction lift will be less at higher altitudes.

3.3 Sound Measurements

The required sound specification, Paragraph 1.7.4.f of 89/392/EEC Machinery Directive, is:

- the guaranteed sound power level (L_{WA}) = 96 dB(A).
- the sound pressure level at operator's location (L_{pA}) = 82 dB(A).

These sound values were determined according to ISO 3744 for the sound power level (L_{WA}) and ISO 6081 for the sound pressure level (L_{pA}) at the operator's location.

3.4 Dimensions

PDT

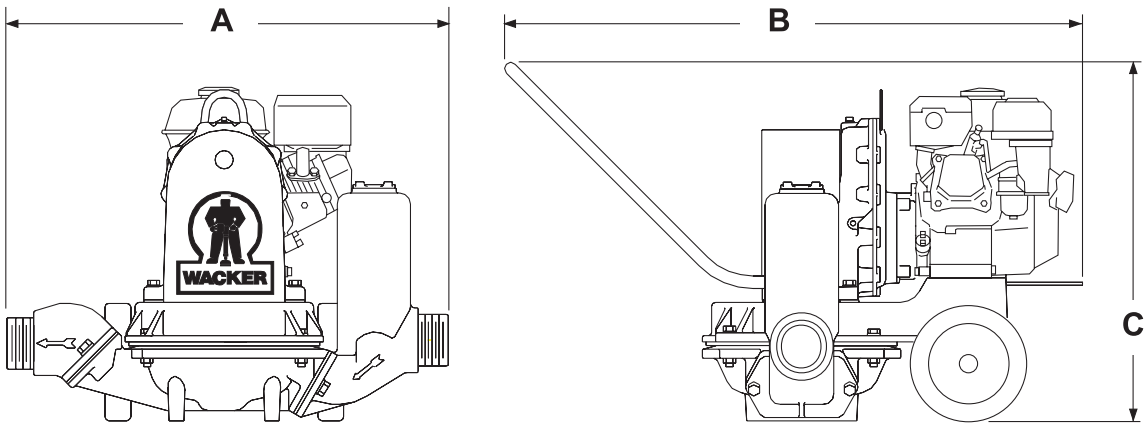

PDI

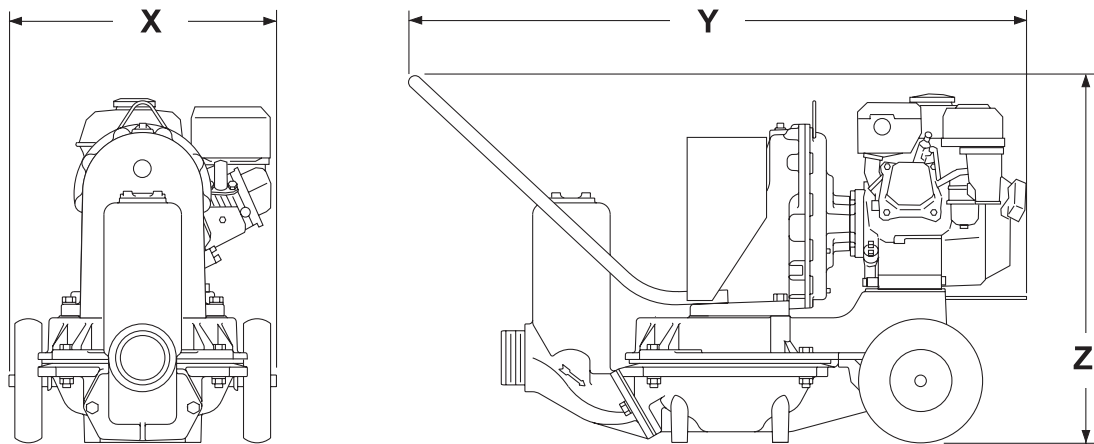

wc ar005095

Item	Revision	A mm (in.)	B mm (in.)	C mm (in.)	X mm (in.)	Y mm (in.)	Z mm (in.)
0007610 PDT2A	107-	635 (25)	1015 (40)	572 (22.5)	-	-	-
	108+	635 (25)	1015 (40)	610 (24)	-	-	-
0007611 PDT2A(I)		635 (25)	1015 (40)	572 (22.5)	-	-	-

0007614 PDT3A	107-	750 (29.5)	1015 (40)	610 (24)	-	-	-
	108+	760 (30)	1015 (40)	635 (25)	-	-	-
0007615 PDT3A(I)		750 (29.5)	1015 (40)	610 (24)	-	-	-
0007616 PDT3A(WW)		750 (29.5)	1015 (40)	610 (24)	-	-	-
0007624 PDI2A	107-	-	-	-	445 (17.5)	1015 (40)	572 (22.5)
	108+	-	-	-	435 (17)	1015 (40)	610 (24)
0007625 PDI2A(I)	107-	-	-	-	445 (17.5)	1015 (40)	572 (22.5)
	108+	-	-	-	435 (17)	1015 (40)	610 (24)
0007628 PDI3A	107-	-	-	-	445 (17)	1015 (40)	610 (24)
	108+	-	-	-	435 (17)	1015 (40)	635 (25)
0007629 PDI3A(I)	107-	-	-	-	445 (17)	1015 (40)	610 (24)
	108+	-	-	-	435 (17)	1015 (40)	635 (25)
0009407 PDI3A(WW)	102-	-	-	-	445 (17)	1015 (40)	610 (24)
	103+	-	-	-	435 (17)	1015 (40)	635 (25)

4. Operation

4.1 Application

This pump is intended for removing clean water or water containing a large amount of debris and suspended solids. The model PD 2A can pump water containing solids up to 30 mm (1.25 in.) diameter. The model PD 3A can pump water containing solids up to 45 mm (1.75 in.) in diameter.

Diaphragm pumps are ideal for pumping mud, slurries and seepage. Typical applications include dewatering of trenches, sewers, pipelines, septic tanks, holding tanks, farm ponds, fields and excavations where a large amount of solids may be present in the water.

4.2 Recommended Fuel

The engine requires regular grade unleaded gasoline. Use only fresh, clean gasoline. Gasoline containing water or dirt will damage fuel system. Consult engine owner's manual for complete fuel specifications.

4.3 Transporting the Machine



Fire hazard. Spilled fuel can ignite and cause severe burns. Lift and transport the machine in an upright position.

When lifting and transporting this machine:

- Close the fuel valve.
- Lift and transport it in an upright position.
- Use the lifting hook **(a)** to lift the machine.
- Use lifting equipment capable of lifting at least 70 kg (150 lbs.).
- Use the lifting hook, rear tie-down bar **(b)**, and the handle **(c)** to secure the machine to the transport vehicle.
- Do not use the wheels or the axle as tie-down points.

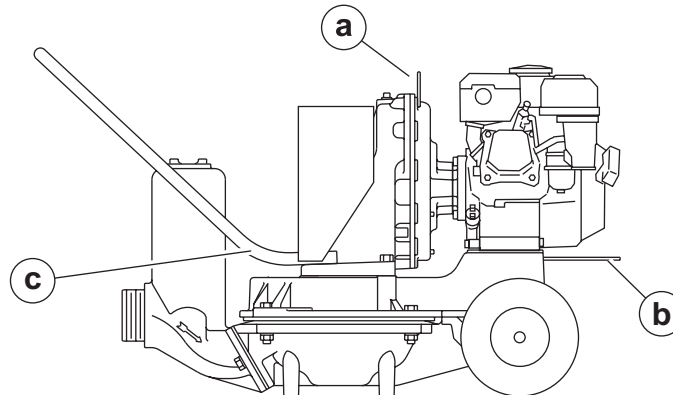

wc_gr005011

4.4 Priming Pump

See Graphic: *wc_gr001064*

Diaphragm pumps are self priming and seldom need to have water added to them before starting. However, if the pump has not been used for several weeks and the rubber valves inside it are dry, adding water through the surge chamber (**f**) will help the valves seal and shorten the amount of time required for the pump to prime.

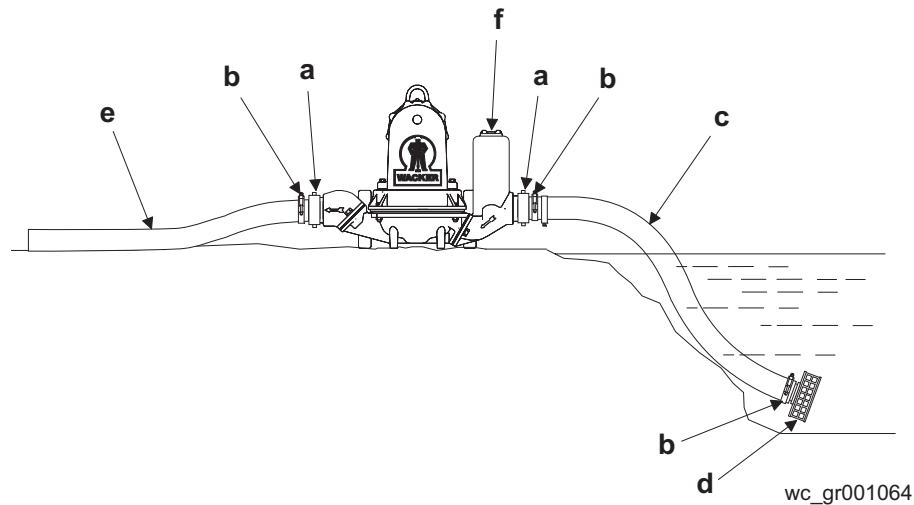

4.5 Before Starting

See Graphic: *wc_gr001064*

- 4.5.1 Read safety instructions at the beginning of manual.
- 4.5.2 Place pump as near to water as possible, on a firm, flat, level surface.
- 4.5.3 Check that hoses are securely attached to pump. Suction hose (**c**) must not have any air leaks. Check that all hose clamps (**b**) and couplings (**a**) are tight. Check that cap on surge chamber (**f**) is tight.
- 4.5.4 Check that discharge hose (**e**) is not blocked. Lay hose out as straight as possible. Remove any twists or sharp bends from hose which may block the flow of water.

Note: Operating the pump with any part of the discharge line positioned higher than 7.5 m (25 ft.) above the pump can cause backflow into the pump and damage pump components.

- 4.5.5 Make sure suction strainer (**d**) is clean and securely attached to end of hose. The strainer is designed to protect the pump by preventing large objects from being pulled into the pump.

Position strainer so it will remain under water as water level drops.

- 4.5.6 Check fuel level, engine oil level, and condition of air cleaner.

4.6 To Start

See Graphic: wc_gr000014

4.6.1 Open fuel valve by moving lever to the right (a1).

Note: If engine is cold, move choke lever to close position (b1). If engine is hot, set choke to open position (b2).

4.6.2 Turn engine switch to “ON” (e1).

4.6.3 Open throttle by moving it slightly to left (d1).

4.6.4 Pull starter rope (c).

Note: If the oil level in the engine is low, the engine will not start. If this happens, add oil to engine. Some engines are equipped with an oil alert light (f) that will come on while pulling the starter rope.

4.6.5 Open choke as engine warms (b2).

4.6.6 Open throttle fully to operate.

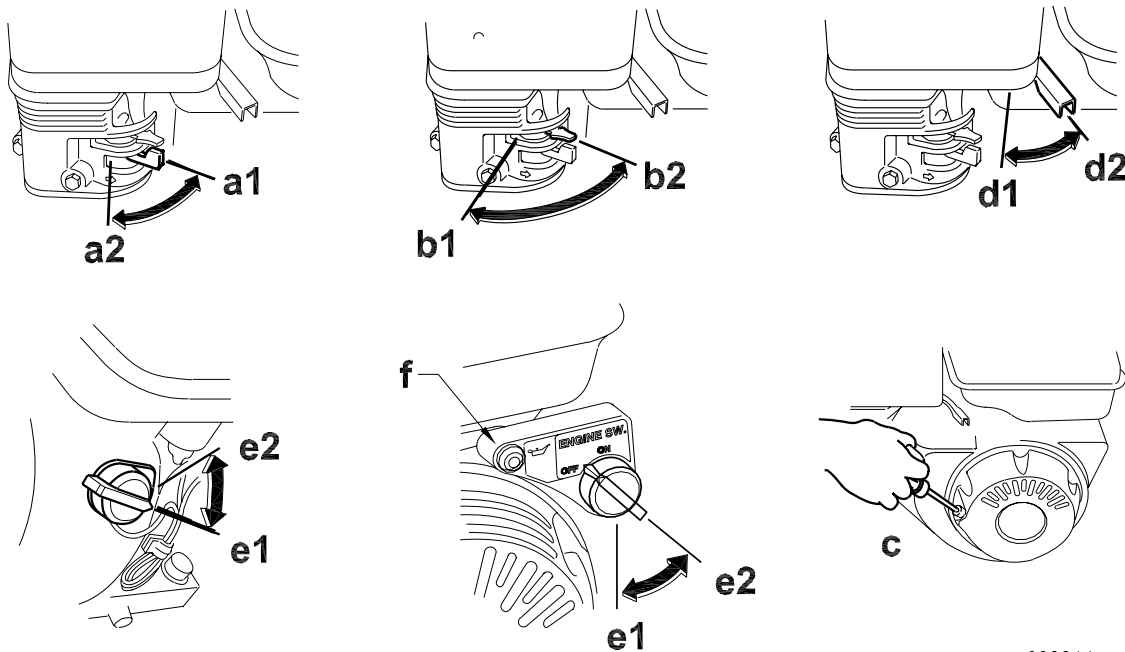

wc_gr000014

4.7 To Stop

See Graphic: wc_gr000014

4.7.1 Reduce engine RPM to idle by moving throttle completely to right (d2).

4.7.2 Turn engine switch to “OFF” (e2).

4.7.3 Close fuel valve by moving lever to the left (a2).

4.8 Operation

Run engine at full speed while operating pump.

Pump should begin pumping water within a minute depending on length of suction hose and height of pump above water. Longer hoses will require more time.

If pump does not prime, check for loose fittings or air leak in suction hose. Make sure strainer in water is not blocked.



DO NOT pump flammable fluids, fuels, corrosive chemicals or fluids containing toxic substances. These fluids can create potentially dangerous health and environmental hazards. Contact local authorities for assistance.

4.9 Accessories

WACKER offers a complete line of fittings, hoses, and clamps to properly connect the pump to match various job conditions.

4.10 Hoses and Clamps

See Graphic: *wc_gr001065*

Suction Hose

Suction hoses **(a)** must be rigid enough not to collapse when pump is operating.

Discharge Hose

Discharge hoses **(b)** are usually thin-walled collapsible hoses. Rigid hoses similar to those used as suction hoses may also be used as discharge hoses.

Note: *Suction and discharge hoses are available from WACKER. Contact your nearest dealer for more information.*

Suction Hose to Inlet Coupling

Two clamps **(c)** are recommended for connection of suction hoses to inlet coupling.

Note: *This connection is important. Even a small air leak on the suction side of pump will prevent the pump from priming.*

Other Hose Connections

For other hose connections, one T-bolt or worm-gear type clamp is usually sufficient to hold hoses in place. In some cases, slight variances in hose diameters may make it necessary to add more clamps in order to maintain tight connections.

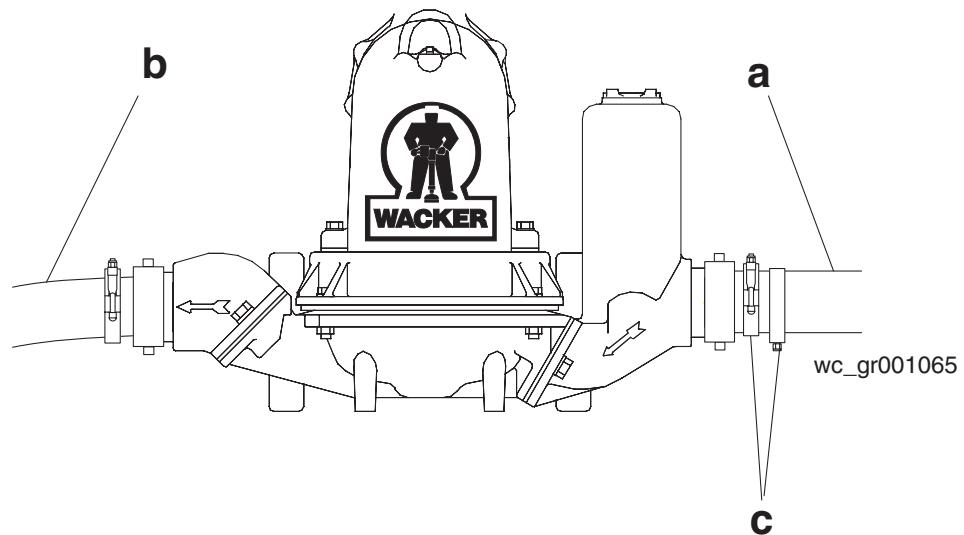

5. Maintenance

5.1 Periodic Maintenance Schedule

The chart below lists basic machine and engine maintenance. Refer to your engine Operator’s Manual for additional information on engine maintenance.

	Daily before starting	After first 20 hrs.	Every 2 weeks or 25 hrs.	Every 100 hrs.	Every 300 hrs.
Check fuel level.	■				
Check engine oil level.	■				
Inspect air filter. Replace as needed.	■				
Check external hardware.	■				
Change engine oil.		■		■	
Check oil level in pump gear case.			■		
Grease pump connecting rod bearing.			■		
Clean sediment cup on engine fuel system.				■	
Check and clean spark plug.				■	
Check and adjust valve clearance.					■
Change oil in pump gear case.					■

5.2 Changing Engine Oil

See Graphic: *wc_gr000022*

5.2.1 Drain the oil while the engine is still warm.

5.2.2 Remove the oil filler plug (**a**) and the drain plug (**b**) to drain the oil.

Note: *In the interests of environmental protection, place a plastic sheet and a container under the machine to collect any liquid that drains off. Dispose of this liquid in accordance with environmental protection legislation.*

5.2.3 Install the drain plug.

5.2.4 Fill the engine crankcase with the recommended oil up to the level of the plug opening (**c**). See section *Technical Data* for oil quantity and type.

5.2.5 Install the oil filler plug.

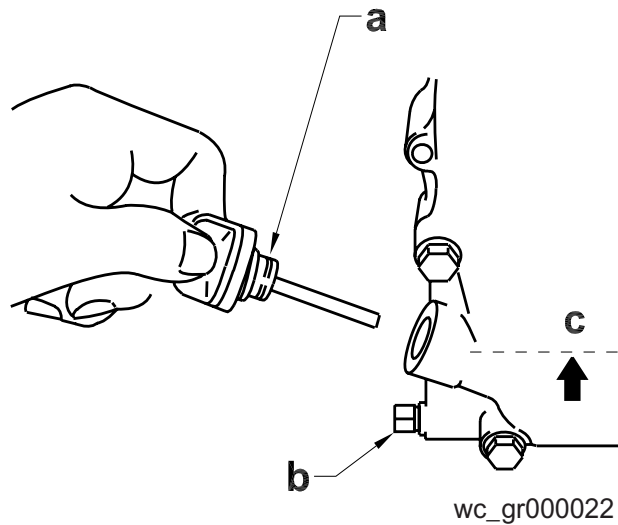

5.3 Servicing Air Cleaner

See Graphic: *wc_gr000025*

The engine is equipped with a dual element air cleaner. Service air cleaner frequently to prevent carburetor malfunction.

NOTICE: NEVER run engine without air cleaner. Severe engine damage will occur.



WARNING

NEVER use gasoline or other types of low flash point solvents for cleaning the air cleaner. A fire or explosion could result.

To service:

- 5.3.1 Remove air cleaner cover (**a**). Remove both elements and inspect them for holes or tears. Replace damaged elements.
- 5.3.2 Wash foam element (**b**) in solution of mild detergent and warm water. Rinse thoroughly in clean water. Allow element to dry thoroughly. Soak element in clean engine oil and squeeze out excess oil.
- 5.3.3 Tap paper element (**c**) lightly to remove excess dirt. Replace paper element if it appears heavily soiled.

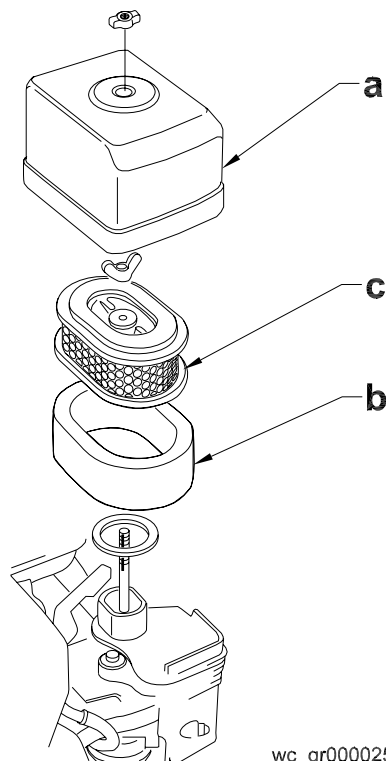

wc_gr000025

5.4 Spark Plug

See Graphic: wc_gr000028

Clean or replace the spark plug as needed to ensure proper operation. Refer to your engine operator's manual.



WARNING

The muffler becomes very hot during operation and remains hot for a while after stopping the engine. Do not touch the muffler while it is hot.

Note: Refer to section *Technical Data* for the recommended spark plug type and the electrode gap setting.

- 5.4.1 Remove the spark plug and inspect it.
- 5.4.2 Replace the spark plug if the insulator is cracked or chipped.
- 5.4.3 Clean the spark plug electrodes with a wire brush.
- 5.4.4 Set the electrode gap (**a**).
- 5.4.5 Tighten the spark plug securely.

NOTICE: A loose spark plug can become very hot and may cause engine damage.

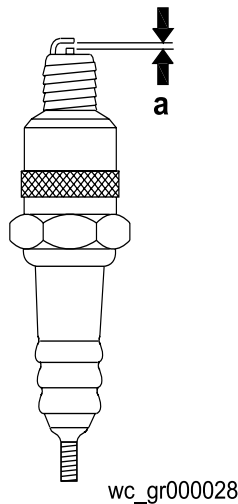

5.5 Gear Case

See Graphic: *wc_gr003450*

Check the oil level in the gear case once a week or every 25 hours of operation.

Remove oil level plug (**h**). Check that oil level is even with plug opening. If oil level is low, add oil through the top fill plug opening (**g**). Do not overfill.

Change oil in gear case once a year or every 300 hours of operation.

Drain oil through drain plug opening (**f**) at bottom of gear case. Add oil through fill plug on top of gear case. See *Technical Data* for oil quantity and type.

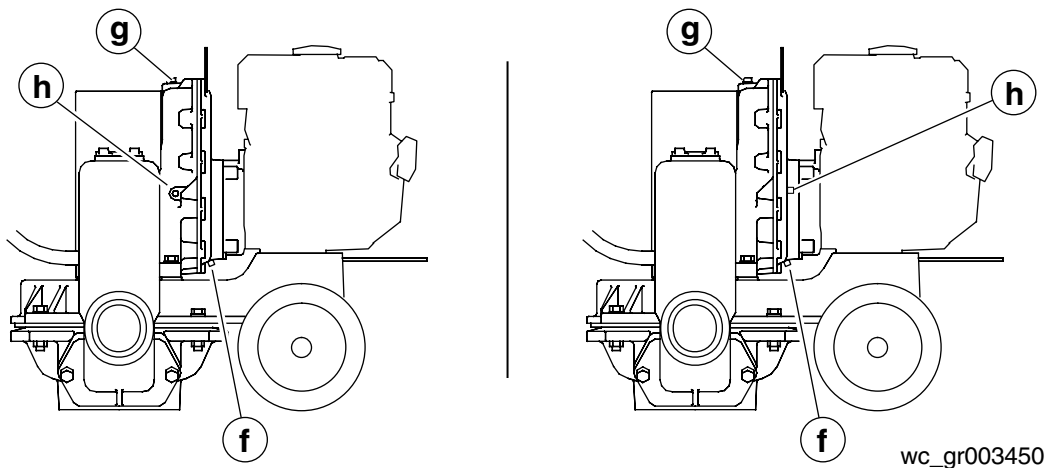

wc_gr003450

5.6 Connecting Rod Bearing

See Graphic: *wc_gr003451*

Grease connecting rod bearing once a week or every 25 hours of operation.

Use a hand operated grease gun. Add grease through grease fitting located behind access hole **(j)** provided on front cover.

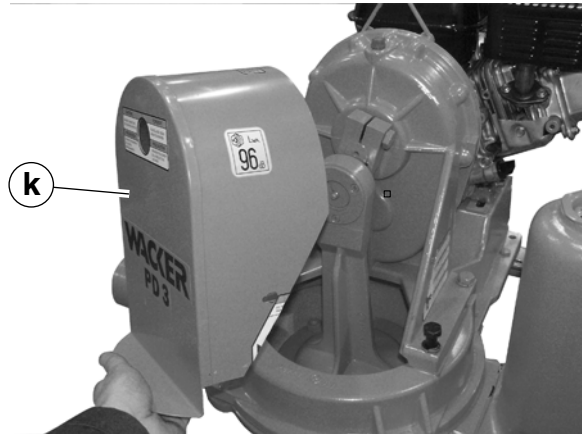

wc_gr003451

5.7 Cleaning Pump

See Graphic: *wc_gr003451*

When pumping heavy sludges or water containing large amounts of dirt and solids, clean the pump often. If allowed to sit in the pump and dry, these materials will harden and could damage the valves or diaphragm inside the pump the next time it is used.

When cleaning pump:

- 5.7.1 Pump clean water through pump for a few minutes after each use to flush dirt from inside pump and hoses.
- 5.7.2 Remove dirt from between engine cooling fins to prevent them from clogging up. This will prevent engine from overheating.
- 5.7.3 Remove front cover **(k)** and clean dirt and grease build-up from connecting rod and inside of front pump cover.

5.8 Cleaning Sediment Cup

See Graphic: *wc_gr000029*

- 5.8.1 Turn the fuel valve off.
- 5.8.2 Remove the sediment cup (a) and the O-ring (b).
- 5.8.3 Wash both thoroughly in a nonflammable solvent. Dry and reinstall them.
- 5.8.4 Turn the fuel valve on and check for leaks.

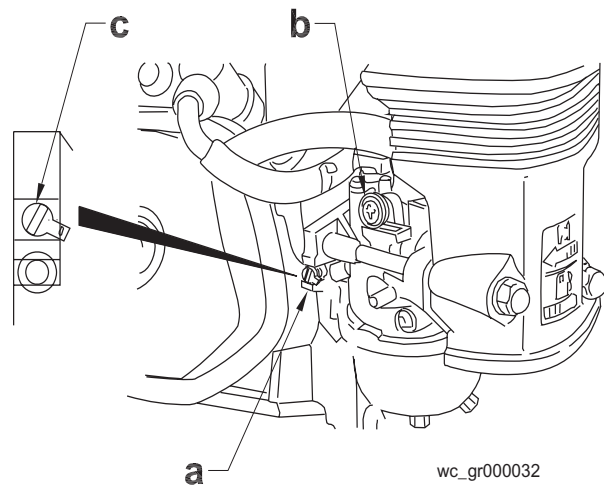
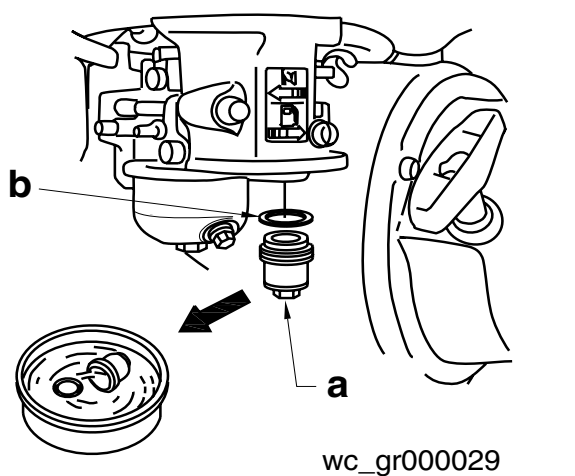

5.9 Carburetor Adjustment

See Graphic: *wc_gr000032*

- 5.9.1 Start the engine and allow it to warm up to operating temperature.
- 5.9.2 Set the pilot screw (a) two turns out. See *Note*.
- 5.9.3 With the engine idling, turn the pilot screw (a) in or out to the setting that produces the highest rpm.
- 5.9.4 After the pilot screw is adjusted, turn the throttle stop screw (b) to obtain the standard idle speed. See *Technical Data*.

Note: On some engines the pilot screw is fitted with a limiter cap (c) to prevent excessive enrichment of the air-fuel mixture in order to comply with emission regulations. The mixture is set at the factory and no adjustment should be necessary. Do not attempt to remove the limiter cap. The limiter cap cannot be removed without breaking the pilot screw.

- 5.9.1

5.10 Storage

If pump is being stored for more than 30 days:



WARNING

NEVER open priming plug, discharge plug, or cover when pump is hot.

- 5.10.1 Remove discharge plug from pump casing and drain out any water left in the housing after pump has cooled.
- 5.10.2 Remove pump cover and clean inside of pump housing. Coat inside of pump with a light film of oil to reduce corrosion. A spray can of oil works well for this.
- 5.10.3 Tape up suction and discharge ports to prevent anything from falling into pump.
- 5.10.4 Change engine oil and follow procedures described in engine manual for engine storage.
- 5.10.5 Cover pump and engine and store in a clean, dry area.

5.11 Troubleshooting

Problem / Symptom	Reason / Remedy
Engine does not start.	<ul style="list-style-type: none"> • Engine problem. See engine manufacturer's service manual for troubleshooting and repair. • Engine oil level too low. Add oil to engine. • Pump housing filled with dirt and debris. Disassemble and clean inside of pump. • Pump gear case damaged. Inspect and repair.
Engine starts but pump does not take in water.	<ul style="list-style-type: none"> • Pump is located too high above or too far away from water. Locate pump closer to water. • Air leak on suction side of pump. Check that hose fittings and cap on surge chamber are tight and sealing properly. • Suction hose damaged or collapsed. Repair or replace hose. • Strainer plugged. Clean or replace strainer. • Dirt collecting inside pump and hoses, blocking flow. Clean inside of pump and flush hoses. • Engine running slow. Check engine speed and adjust. See chapter <i>Technical Data</i> for engine speed. • Pump valves damaged or not seating properly. Check for stones and gravel imbedded in valves. Replace valves. • Diaphragm loose or damaged. Inspect diaphragm for damage. Replace and tighten.
Pump output low.	<ul style="list-style-type: none"> • Pump located too high above or too far away from water. Locate pump closer to water. • Suction strainer or intake line partially plugged. Clean hose line and strainer. • Discharge hose is kinked or end is blocked. Check that hose lies straight and flows freely. • Discharge hose too narrow. Use hose of equal diameter or larger than suction hose.

5.12 Decommissioning

5.12.1 When this machine has reached the end of its useful life, practice environment-friendly recycling.

- Do not dispose of the machine in normal garbage containers.
- Dispose of the machine in accordance with local environmental recycling regulations.
- Take the machine to your local designated recycling location.

5.12.2

PORTABLE PUMPS

www.aem.org



SAFETY MANUAL

FOR OPERATING AND MAINTENANCE PERSONNEL

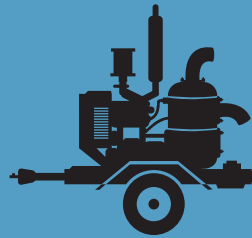
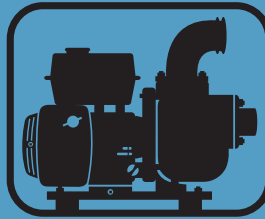

SAFETY ALERT SYMBOL



This Safety Alert Symbol means
ATTENTION is involved!

The Safety Alert Symbol identifies important safety messages on machines, safety signs, in manuals, or elsewhere. When you see this symbol, be alert to the possibility of personal injury or death. Follow the instructions in the safety message.

Why is SAFETY important to YOU?

3 BIG REASONS

- **Accidents KILL or DISABLE**
- **Accidents COST**
- **Accidents CAN BE AVOIDED**

NOTICE OF COPYRIGHT PROTECTION

AEM Safety Manuals are protected as a copyrighted work with ownership duly registered with the Copyright Office, Washington, D.C. Any reproduction, translation, decompiling or other use of an AEM Safety Manual, or portion thereof, or the

creation of derivative works based on an AEM Safety Manual, without the prior written approval of AEM is expressly prohibited. Copyright infringement can result in civil and criminal sanctions, damages and other penalties being imposed.

Copyright © 2004— Association of Equipment Manufacturers

1

REFERENCES

The following is a partial list of referenced material on safe operating practices:

U.S. Department of Labor publishes safety and health regulations and standards under the authority of the Occupational Safety and Health Act for the general construction and mining industries.

U.S. Department of Labor
Washington, DC 20210

NFPA — National Fire Protection Association
P.O. Box 9101
1 Battery March Park
Quincy, MA 02269-9101

SAE — Society of Automotive Engineers, Inc.
400 Commonwealth Drive
Warrendale, PA 15096
Publishes a list, "Operator Precautions" SAE J153
MAY 87.

AEM — Association of Equipment Manufacturers
111 East Wisconsin Avenue
Milwaukee, WI 53202

CONTENTS

	Page	Section
FOREWORD.....	4	
FOLLOW A SAFETY PROGRAM	5	1
PERFORM MAINTENANCE SAFELY	7	2
PREPARE FOR SAFE OPERATION	9	3
WORK SAFELY – Pumps In General	10	4
WORK SAFELY – Engine Driven Pumps.....	13	5
WORK SAFELY – Electric Motor Driven Pumps.....	15	6
WORK SAFELY – Submersibles	17	7
TEST YOUR KNOWLEDGE	19	8
FINAL WORD TO THE USER	20	9

FOREWORD

This safety manual is intended to point out some of the basic situations which may be encountered during the normal operation and maintenance of your equipment, and to suggest possible ways of dealing with these conditions.

Additional precautions may be necessary, depending on application, pump type, configuration and attachments used, conditions at the work-site or in the maintenance area. The manufacturer has no direct control over pump application, operation, inspection, lubrication or maintenance. Therefore, it is your responsibility to use good, safe, practices in these areas.

The information provided in this manual supplements the specific information about your pump that is contained in the manufacturer's manual(s). Other information which may affect the safe operation of your pump may be contained on safety signs, decals, markings, insurance requirements, employer's safety programs, safety codes, local, state/provincial and federal laws, rules and regulations, contracts, agreements and warranties.

It is your responsibility to read and understand this safety manual and the manufacturer's manual(s) before operating your pump. This safety manual takes you step-by-step through your working day. If you do not understand any of this information, or if errors or contradictions seem to exist, consult with your supervisor before operating your pump.

IMPORTANT: If you do not have the manufacturer's manual(s) for your particular pump, get a replacement manual from your employer, equipment dealer, or manufacturer of your pump. Keep this safety manual and the manufacturer's manual(s) with your pump.

Unauthorized modifications of pumps create hazards. Pumps must not be modified or altered unless prior approval is obtained from the manufacturer.

DO NOT PUMP VOLATILE/FLAMMABLE OR CAUSTIC/CORROSIVE LIQUIDS.

REFER TO THE OWNER'S MANUAL OR CONSULT WITH THE MANUFACTURER FOR THE PROPER PUMP MATERIALS IF YOU ARE TO PUMP HAZARDOUS CAUSTIC/CORROSIVE LIQUIDS.

FOLLOW A SAFETY PROGRAM

KNOW THE RULES

Every employer is concerned about safety. Safe operation and proper maintenance of your pump can prevent accidents. **KNOW** the rules — **LIVE** by them. (FIG. 1)

When starting work at a new site, check with the designated safety coordinator for specific safety instructions. **DON'T LEARN SAFETY THE HARD WAY.**

Know the meaning of all hand signals, signal flags, signs and markings.

Know the traffic rules used at the work site. Know who the signal man is; watch and obey his signals.

Know where the fire extinguishers and first aid kits are kept and how to use them. Know where to get proper aid and assistance when needed.

Use common sense to avoid accidents. If an accident does occur, be prepared to react to it quickly and effectively.

NEVER PANIC.

Remember that **YOU are the key to safety.** Good safety practices not only protect you but also protect the people around you. Study this manual and the manufacturer's manual(s) for your specific pump. Make them a working part of your safety program. Keep in mind that this safety manual is written for only this type of equipment. Practice all other usual and customary safe working precautions, and above all (FIG. 1).

REMEMBER — SAFETY IS UP TO YOU

**YOU CAN PREVENT
SERIOUS INJURY OR DEATH**



FIG. 1

1

5

FOLLOW A SAFETY PROGRAM

KNOW WHAT IT IS?

Consult your supervisor for specific instructions and personal safety equipment required.

For instance, you may need:

- Hard Hat
- Safety Shoes
- Eye Protection
- Respirators
- Heavy Gloves
- Reflector Vests
- Hearing Protection
- Face Protection
- Back Supports
- Other job related specific items

Do not wear loose clothing or any accessory — flopping cuffs, untied shoe-laces, dangling neckties and scarves, rings, wrist watches, or other jewelry — that can catch on protruding or moving parts or controls. Long hair should be securely bound to prevent entanglement with moving parts. (FIG. 3)



FIG. 2



FIG. 3

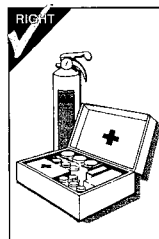

FIG. 4

BE ALERT!

Know where to get assistance. Know how to use a first aid kit and fire extinguisher or fire suppression system. (FIG. 4)

BE AWARE!

Take advantage of training programs offered.

Safety programs should require that one person at each jobsite be assigned the overall responsibility and authority for safety. Know who the person is, and **COMMUNICATE** with them.

Know what the jobsite rules are, and **FOLLOW THE RULES.** Be safety conscious, responsible and reliable. Think about safety **BEFORE** something happens.

BE CAREFUL!

Human error is caused by many factors: carelessness, fatigue, overload, preoccupation, incompatibility between operator and the equipment, drugs, and alcohol to name a few. Damage to the equipment can be fixed in a short period of time, but injury, or death has a lasting effect.

For your safety and safety of others, encourage your fellow workers to act within safety rules.

1

6

PERFORM MAINTENANCE SAFELY

CLOTHING AND PERSONAL PROTECTIVE ITEMS

ALWAYS wear appropriate safety glasses, goggles or face shield when working. (FIG. 2) Proper eye protection can keep flying particles from grinding, drilling or hammering operations, or fluids such as fuel, solvents, lubricants and brake fluids from damaging your eyes. Normal glasses do NOT provide adequate protection.

ALWAYS wear a hard hat and safety shoes. (FIG. 2) ALWAYS wear hearing protectors when exposed to high noise levels for extended periods. ALWAYS wear a respirator when painting or exposed to dusty conditions. ALWAYS keep your pockets free of loose objects which can fall out and drop into machinery. (FIG. 5) Heavy gloves should be worn for many operations.

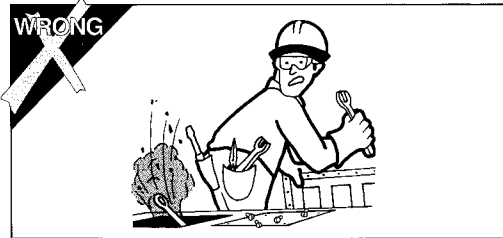

FIG. 5

EXHAUST FUMES

Engine exhaust fumes can cause sickness or death. If it is necessary to run an engine in an enclosed area, remove the exhaust fumes from the area with an exhaust pipe extension. If you do not have an exhaust pipe extension, be positive the area is adequately ventilated. (FIG. 6)



FIG. 6

HEAVY PARTS

Handle tools and heavy parts sensibly — with regard for yourself and other persons. Lower items — don't throw or drop them.

ALWAYS use proper hoisting equipment for lifting heavy loads.

ALWAYS use a back brace when lifting by hand.

2

7

PERFORM MAINTENANCE SAFELY

FIRE PREVENTION

Whenever possible use a nonflammable solvent to clean parts. Do not use gasoline or other fluids that give off harmful vapors.

If flammable fluids, such as gasoline or diesel fuel, must be used, extinguish open flames or sparks and DO NOT smoke.

Store dangerous fluids in a suitable place, in approved containers which are clearly marked. NEVER smoke in areas where flammable fluids are used or stored. (FIG. 7)

Use proper nonflammable cleaning solvents. Follow solvent manufacturer's instructions for use.

Always remove all flammable material in the vicinity of welding and/or burning operations.

ALWAYS keep the floor in the work area clean and dry. Oily, greasy floors can easily lead to falls. Wet spots, especially near electrical equipment, can be hazardous. (FIG. 7)

Know where fire extinguishers are kept — how they operate — and for what type of fire they are intended.

Check readiness of any fire detectors and fire suppression systems.



FIG. 7

2

PREPARE FOR SAFE OPERATION

LEARN TO BE SAFE

NEVER operate a pump which is new to you without first being instructed in its proper operation. READ the operator's manual. If one has not been provided, GET ONE AND STUDY IT BEFORE OPERATING THE PUMP.

Know the meaning of all identification symbols on your controls and gauges. (FIG. 8)

Know the location of the emergency shut-down control if the machine is so equipped.

Before attempting to operate the pump, know the capabilities and limitations of the pump. Familiarize yourself with controls and instruments — their locations and functions.

Keep hands, levers and knobs clean of oil or grease to prevent slipping.

Carefully read and follow the instructions on all safety signs and decals on the pump. Keep safety signs in good condition. Replace missing or damaged safety signs.



FIG. 8

CHECK IT OUT!

Know what safety devices your machine is equipped with ... and see that each item is securely in place and in operating condition. (FIG. 9)

For example:

- Drawbar Coupling Chains and Pins
- Alarms and Warning Lamps
- Reflectors
- Guards and Shields
- Drain Covers, Plugs, and Caps
- Shut-Down Devices
- Leveling Jacks
- Pressure Relief Devices
- Lifting Devices

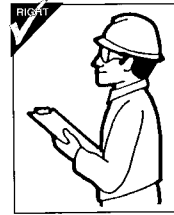

FIG. 9

NEVER START OR OPERATE A PUMP KNOWN OR SUSPECTED TO BE DEFECTIVE OR MALFUNCTIONING.

If your daily check uncovers any items that need attention — repair, replacement, or adjustment — report them promptly. The most minor malfunction could be the result of more serious trouble — or can cause it, if pump is operated. When in doubt, attach an OSHA Lockout/Tagout device tag to the control panel to disconnected electrical power supply at breaker, on electrically driven pumps and disconnect the battery and/or spark plug wire on engine driven pumps.

3

9

WORK SAFELY — Pumps In General

SAFE WORKING PROCEDURES

USE COMMON SENSE! Most accidents can be avoided by using common sense and concentrating on the job to be done.

ONLY EXPERIENCED AND QUALIFIED personnel should install and operate pump equipment.

KNOW THE PROPER starting procedure for your equipment. Follow the manufacturer's operation manual ... to the letter.

DO NOT operate a pump without all guards and shields in place. (If OSHA required guards are damaged or misplaced, contact the manufacturer for a replacement.)

When **lifting pump** use only lifting equipment in good repair and with adequate capacity. Follow manufacturer's lifting recommendation.

Check all lubricant levels before pump installation in accordance with manufacturer's maintenance programs.

Keep hands and feet clear of moving parts. DO NOT stick fingers into a pump when in operation. Check suction strainer and hose regularly for proper submergence and to be sure it is free of obstructions.

NEVER operate a self-priming pump unless the volute is filled with liquid. The pump will not prime when dry.

PUMP only liquids for which the pump has been designed to handle.

DO NOT pump flammable, corrosive or caustic materials unless the pump and piping are explicitly designed for that purpose.

NOTE the direction of rotation — operation of a pump in the wrong direction can cause the impeller to unscrew and damage the volute case.

A pump should not be operated against a closed valve or other no flow conditions. Refer to the pump manufacturer's recommended practice for start-up, operation and shut-down procedures. **DO NOT** close down or restrict a discharge hose. **Be careful** of discharge hose whipping under pressure.

4

WORK SAFELY – Pumps In General

MAKE CERTAIN that whatever is to be connected to the pump is not subjected to pressures greater than those given in the manufacturer's instructions.

MAKE CERTAIN all connections are securely made and hoses under pressure are secured, with appropriate safety devices, to prevent whipping.

BE AWARE OF LIGHTNING. Stay clear of the pumping equipment during electrical storms. It can attract lightning. (FIG. 10)

OVERHEATING PRECAUTIONS

Overheated pumps can cause severe damage to the equipment and can cause severe physical burns and injury.

Operating a pump with the suction and/or discharge valve closed is a principal cause of overheating. Approach cautiously any pump that has been in operation.

DO NOT remove hoses from a pump until the system is properly cooled to ambient temperature.

DO NOT remove the cover plate or drain plugs from any overheated pump. Allow the pump to cool. Check pump temperature before opening fill port or drain plug.

If overheating of the pump casing occurs:

- **STOP** the pump immediately.
- Allow the equipment to **cool completely**.
- Slowly and cautiously **vent the pump**.
- **Refer to the manufacturer's instruction manual** before restarting the unit.
- Remove hoses carefully. Heated water can be in hoses and static head produces pressure.

4

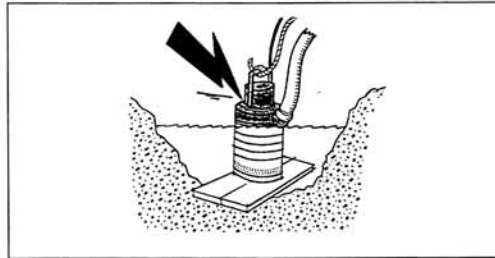

FIG. 10

11

WORK SAFELY – Pumps In General

BEFORE STARTING

Check the pump thoroughly at delivery for any shipping damage.

Locate the pump in an accessible location, as close to the liquid as possible.

Secure the pump after it is placed in its intended operating position so it does not tip, roll, slide or fall.

IMMEDIATELY ON STARTING THE PUMP

Observe gauges, instruments and warning lights to ensure that they are functioning and their readings are within the normal operating range.

- Be sure the immediate work area is safe for operation.
- Operate controls; make certain all operate properly and "feel" right. Accustom yourself to the "feel" of the equipment.
- Listen for any unusual noises, smell for any unusual odors; look for any signs of trouble.
- Be sure to open all manual valves slowly to prevent **WATER HAMMER**.
- Check all warning and safety devices and indicators.

• If safety-related defects or malfunctions are detected, **SHUT DOWN** the equipment. Correct the problem, or notify your supervisor. **DO NOT OPERATE EQUIPMENT WITH DEFECTS OR MALFUNCTIONS UNTIL CORRECTED.**

• **If an unsafe condition cannot be remedied immediately, notify your supervisor and tagout/lockout** the pump on the start switch and/or appropriate, prominent location. (FIG. 11)

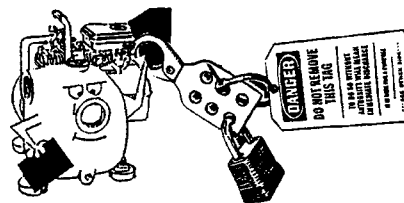

FIG. 11

4

WORK SAFELY – Engine Driven Pumps

SAFE WORKING PROCEDURES

Do not jump start engine battery.

When operating internal combustion engines in an enclosed area, always make provisions to pipe exhaust fumes to the outside.

EXHAUST FUMES CAN KILL: Do not operate engine driven pump equipment in a confined or enclosed space without adequate ventilation.

Exhaust gases are odorless and deadly poison.

DO NOT TOUCH: The exhaust system components get very hot and stay hot for some time after shutting the engine off.

Follow engine manufacturer's instructions explicitly on hand cranking.

Do not shut down high head pumps quickly:

- A) Throttle back slowly
- B) Open by-pass line
- C) Should have a check valve
- D) Slowly close gate valve on discharge if so equipped.

Check for fuel, oil and hydraulic fluid leaks, worn and damaged hoses/lines or power cables.

Refueling

When refueling, the following precautions must be followed:

- Add fuel of proper type and grade, only when the pump is not running and engine is cool.
- Fuel in well ventilated area.
- Turn off all electrical switches.
- Keep lighted smoking materials, flames or spark producing devices at a safe distance while refueling.
- Keep fuel nozzle in contact with tank being filled, or provide a ground to prevent static sparks from igniting fuel.
- **Do not spill fuel on hot surfaces.**
- Clean up spillage immediately.
- Do not start engine until fuel cap is secured to the fuel tank.
- **Always** make sure that fuel is being put in the fuel tank, motor oil in the proper location and hydraulic oil into hydraulic oil reservoirs.

5

13

WORK SAFELY – Engine Driven Pumps

Maintenance and Repair

All installations, operations and maintenance should be in accordance with pump and engine manufacturer's recommended operation and maintenance program. These manuals should be kept available with the equipment.

Maintenance work can be **hazardous** if not done in a careful manner. All personnel should realize the hazards and strictly follow safe practices.

NEVER perform any work on the equipment unless authorized to do so.

BEFORE ANY maintenance **work** is to be done, a LOCKOUT/TAGOUT standard device and procedure should be implemented. Prior to removal of LOCKOUT/TAGOUT, the equipment must be fully operational and all personnel accounted for. Except in cases of emergency, the removal of the LOCKOUT/TAGOUT should be done **ONLY** by the initiating person prior to the return to start-up (see page 12, Fig. 11).

BEFORE doing any major work, disconnect the ignition and battery if so equipped.

Always replace safety devices removed during service or repair before returning pump to operation.

Battery Servicing

- **Always wear** safety glasses and gloves when servicing or working with batteries.
- **Before servicing battery**, turn off electrical systems, then disconnect ground terminal clamp. Before installing a battery, turn off electrical equipment, then connect the battery ground clamp **last**.
- **Maintain** electrolyte at the recommended level. Check level frequently. Add distilled water to batteries only when starting up, never when shutting down.
- **Use a flashlight** to check level. **NEVER** use a flame.
- **Do not short** across battery terminals — the spark could ignite the battery gases.

Battery acids will **burn skin**, eat holes in clothing, and can **cause blindness** if splashed in eyes.

If you spill acid on yourself flush skin immediately with lots of water. Apply baking soda to help neutralize the acid. If acid gets into the eyes, flush immediately with large amounts of water and seek proper medical treatment immediately.

5

14

WORK SAFELY – Electric Motor Driven Pumps

SAFE WORKING PROCEDURES

Allow only qualified personnel to INSTALL, WIRE AND OPERATE electric motor driven pumps. Whenever electricity is present there is the possibility of **electrocution**.

NEVER use a pump/motor in an explosive atmosphere if it is not exclusively designed for the application.

Always ground electrical units.

Make certain to connect pump motor to the right phase and voltage.

Do not run pump if voltage is not within limits.

Make sure motor rotation is in accordance with impeller rotation (which should be indicated somewhere on the pump — check the manufacturer's manual).

Make all electrical installations in accordance with National Electric Code, State and Local electrical codes.

Never use gas piping as an electrical ground.

Make sure the related electrical circuits are dead and locked out before performing any maintenance.

Follow motor manufacturer's recommended maintenance and operation instructions.

If circuit breaker or fuse is tripped, examine the system for the problem before restarting pump.

NEVER use the power cord to aid lifting the pump.

NEVER operate a pump with a plug-in type power cord without a ground fault circuit interrupter.

NEVER use cords with frayed, cut or brittle insulation. Check the cord on the pump for nicks in the insulation and for sound connections to the ground fault interrupter plug and motor.

NEVER let extension cords or the plug connections lay in water. Locate the pump so that the cord cannot fall into any water or be submerged by rising water, unless the pump is designed for such use.

NEVER handle energized power cords with wet hands.

MOTOR OVERLOAD: do not exceed the manufacturer's recommendation for maximum lift or discharge head. See manufacturer's published curve for proper sizing of motors. A misapplied motor can overheat.

6

15

WORK SAFELY – Electric Motor Driven Pumps

Pump Maintenance and Repair

MAKE SURE the pump is disconnected from the power source or the appropriate circuits are dead and OSHA Lockout/Tagout is applied before doing any maintenance or repair work on the pump.

Maintenance work can be **hazardous** if not done in a careful manner. All personnel should realize the hazards and strictly follow safe practices.

NEVER perform any work on the equipment unless authorized to do so. (FIG. 11) Before performing any maintenance or repair work, consult the manufacturer's instruction manual for recommended procedures.

Pumps with float switches or other automatic devices can start without warning if not properly locked out.

BEFORE ANY maintenance work is to be done, a LOCKOUT/TAGOUT standard device and procedure should be implemented. Prior to removal of LOCKOUT/TAGOUT, the equipment must be fully operational and all personnel accounted for. Except in cases of emergency, the removal of the LOCKOUT/TAGOUT should be done **ONLY** by the initiating person prior to the return to start-up.

ALWAYS replace safety devices removed during the service or repair before returning pump to operation.

NEVER use the power cord to aid in lifting the pump.

Sizing Extension Cords

Use the following chart to select the correct size extension cord to prevent excessive amperage draw or voltage drop which would cause the motor to overheat. **Cables that are too long or coiled** can cause a voltage drop. **Be aware** that strong sunlight can cause a voltage drop.

Amperes	Wire Gauge and Cord Length (in feet)		
	50	100	150
6	16	16	14
8	16	14	12
10	16	14	12
12	14	14	12
14	14	12	10
16	12	12	10

6

WORK SAFELY – Submersibles

SAFE WORKING PROCEDURES

ALLOW only qualified personnel to INSTALL, WIRE and OPERATE submersible pumps.

Whenever electricity is present there is the possibility of **electrocution**.

NEVER use a pump/motor in an explosive atmosphere, if it is not exclusively designed for that application.

ALWAYS ground the pump.

Make certain to connect the pump to the right phase and voltage.

DO NOT run the pump if voltage is not within limits. **Make all electrical installations** in accordance with National Electric Code, State and Local electrical codes.

Mount electrical control box in a vertical position, protected from the elements.

NEVER attempt to use the power cord or hydraulic hoses as a lifting or lowering device for submersibles. Attach a lifting cable to the manufacturer's recommended attachment point on the pump for lowering and lifting the pump. (FIG. 12)

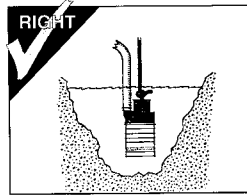

FIG. 12

NEVER position the pump directly on a soft, loose bottom. To attain maximum capacity and prevent excessive wear, position the pump so it will not burrow itself into sand or clay. Stand the pump on a plank, a bed of coarse gravel, within a perforated container, on a suitable floatation device, or retain it hanging freely by a lifting cable. (FIG. 13)

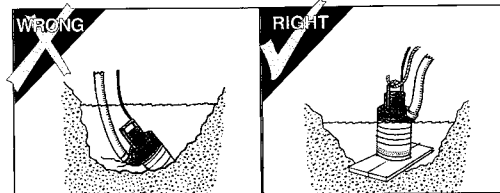

FIG. 13

7

17

WORK SAFELY – Submersibles

Pump Maintenance and Repair

MAKE SURE the pump is disconnected from the power source or the appropriate circuits are dead and OSHA Lockout/Tagout is applied before doing any maintenance or repair work on the unit.

Maintenance work can be **hazardous** if not done in a careful manner. All personnel should realize the hazards and strictly follow safe practices.

NEVER perform any work on the equipment unless authorized to do so. Before performing any maintenance or repair work, consult the manufacturer's instruction manual for recommended procedures.

BEFORE ANY maintenance work is to be done, a LOCKOUT/TAGOUT standard device and procedure should be implemented. Prior to removal of LOCKOUT/TAGOUT, the equipment must be fully operational and all personnel accounted for. Except in cases of emergency, the removal of the LOCKOUT/TAGOUT should be done **ONLY** by the initiating person prior to the return to start-up.

Check oil level ONLY when pump is cool.

USE ONLY recommended oil per manufacturer's recommendation.

INSPECT ELECTRICAL WIRING for worn or damaged insulation. **INSTALL** new wiring if wires are damaged. **After repairs are made, clean the equipment before putting the pump back into position.**

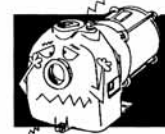

7

TEST YOUR KNOWLEDGE

Do you understand this AEM SAFETY MANUAL AND ITEMS SUCH AS ...

- Your safety program?
 - Your pump manufacturer's manual(s)?
 - Proper clothing and personal safety equipment?
 - Your pump's controls, warning signs and devices, and safety equipment?
 - How to properly inspect, mount, and start your pump?
 - How to check your pump for proper operation?
 - Your work area and any special hazards that may exist?
- Proper operating procedures?
 - Proper shutdown procedures?
 - Proper maintenance procedures?
 - Proper loading and unloading procedures for transporting?
 - Under what conditions you should not operate your pump?

If you do not understand any of these items, consult with your supervisor BEFORE operating your equipment!

8

19

FINAL WORD TO THE USER

Remember that **YOU are the key to safety**. Good safety practices not only protect you but protect the people around you.

You have read this safety manual and the manufacturer's manual(s) for your specific pump. Make them a working part of your safety program. Keep in mind that this safety manual is written for only this type of equipment.

Practice all other usual and customary safe working precautions, and above all —

**REMEMBER
SAFETY IS UP TO YOU
YOU CAN PREVENT SERIOUS
INJURY OR DEATH**

9

20

This manual is another in a series on the safe operation of machinery published by AEM.
For additional publications visit our web site at www.aem.org.



Association of Equipment Manufacturers

Toll free 1-866-AEM-0442

e-mail aem@aem.org

www.aem.org

**EC DECLARATION OF CONFORMITY
CE-KONFORMITÄTSERKLÄRUNG
DECLARACIÓN DE CONFORMIDAD DE LA CE
DÉCLARATION DE CONFORMITÉ C.E.**

WACKER CORPORATION, N92 W15000 ANTHONY AVENUE, MENOMONEE FALLS, WISCONSIN USA

AUTHORIZED REPRESENTATIVE IN THE EUROPEAN UNION BEVOLLMÄCHTIGTER VERTRETER FÜR DIE EUROPÄISCHE GEMEINSCHAFT REPRESENTANTE AUTORIZADO EN LA UNIÓN EUROPEA REPRÉSENTANT AGRÉÉ AUPRÈS DE L'UNION EUROPÉENNE	WACKER CONSTRUCTION EQUIPMENT AG Preußenstraße 41 80809 München
---	--

hereby certifies that the construction equipment specified hereunder: / bescheinigt, daß das Baugerät: / certifica que la máquina de construcción: / atteste que le matériel :

1. Category / Art / Categoría / Catégorie

**Water Pump Units
Wasserpumpen
Equipos de Bomba de Agua
Groupe Motopompe à Eau**

2. Type - Typ - Tipo - Type

PDT 2A, PDT 3A, PDI 2A, PDI 3A, PDT 2, PDT 3, PDI 2, PDI 3

3. Item number of equipment / Artikelnummer / Número de referencia de la máquina / Numéro de référence du matériel :

**0007610, 0007614, 0007624, 0007625, 0007628, 0007629, 0009407, 0009494, 0009495, 0009489,
0009491, 0009492**

4. Net installed power / absolute installierte Leistung / Potencia instalada neta / Puissance installée nette :

**PDT 2A, PDT 3A, PDI 2A, PDI 3A 3 kW
PDT 2, PDT 3, PDI 2, PDI 3 3.2 kW**

Has been sound tested per Directive 2000/14/EC / In Übereinstimmung mit Richtlinie 2000/14/EG bewertet worden ist / Ha sido ensayado en conformidad con la norma 2000/14/CE / A été mis à l'épreuve conforme aux dispositions de la directive 2000/14/CEE :

Conformity Assessment Procedure / Konformitätsbewertungsverfahren / Procedimiento para ensayar conformidad / Procédé pour l'épreuve de conformité	Measured sound power level / Gemessener Schalleistungspegel / Nivel de potencia acústica determinado / Niveau de puissance acoustique fixé	Guaranteed sound power level/ Garantierter Schalleistungspegel / Nivel de potencia acústica garantizado / Niveau de puissance acoustique garanti
Annex V / Anhang V Anexo V / Annexe V	95 dB(A)	96 dB(A)

and has been produced in accordance with the following standards:
und in Übereinstimmung mit folgenden Richtlinien hergestellt worden ist:
y ha sido fabricado en conformidad con las siguientes normas:
et a été produit conforme aux dispositions des directives européennes ci-après :

**2000/14/EC
2002/88/EC
89/336/EEC
98/37/EEC**



William Lahner
Vice President of Engineering

Dan Domanski
Manager, Product Engineering

09.02.05

Date / Datum / Fecha / Date

WACKER CORPORATION

